



标准&定制开关连接器产品制造商
DONG GUAN XI BANG ELECTRONICS CO., LTD.

规格书

SPECIFICATION

CUSTOMER NAME 客户名称: _____
 CUSTOMER NO. 客户编号: _____
 SERIES 系列: 检测开关
 MODEL NO. 型号: XB-TM-V-101A
 DRAWING NO. 图形号: Detector Switches

If specification of this product meets your request, please confirm all the items of it and return to us with signature and stamp, it will be basis of our production and record. Thanks your cooperation in advance!

若此产品规格符合贵司要求，敬请确认此规格书内所有项目
 并签名和盖章后回传给我司，以作我司产品制作之
 依据和存档之用，多谢合作！

EXAMINE & APPROVAL 审批

APPROVE 接受	NOT APPROVE 不接受
SIGNATURE 签署 STAMP 盖章 DATE 日期	

PREPARED BY. 制表人	CHECKED BY. 校对	APPROVED BY. 审核	APPROVAL BY. 批准
<div style="border: 1px solid red; padding: 2px;">研发部</div> <div style="border: 1px solid red; padding: 2px;">戴海明</div> <div style="border: 1px solid red; padding: 2px;">2022. 06. 08</div>	<div style="border: 1px solid red; padding: 2px;">品质部</div> <div style="border: 1px solid red; padding: 2px;">黄自清</div> <div style="border: 1px solid red; padding: 2px;">2022. 06. 08</div>	<div style="border: 1px solid red; padding: 2px;">工程部</div> <div style="border: 1px solid red; padding: 2px;">庞军</div> <div style="border: 1px solid red; padding: 2px;">2022. 06. 08</div>	<div style="border: 1px solid red; padding: 2px;">总经办</div> <div style="border: 1px solid red; padding: 2px;">吴量</div> <div style="border: 1px solid red; padding: 2px;">2022. 06. 08</div>

东莞市溪榜电子有限公司

Dong guan Xi Bang Electronics Co., Ltd
 地址: 广东省东莞市黄江镇合路工业区
 Address: He Lu Industrial Zone, Huangjiang Town
 , Dongguan City, Guangdong Province
 Tel: (0769)82055138/82056828
 Fax: (0769)83663452

邮箱: admin@alspr.com switch@alspr.com
<http://www.alspr.cn/> <http://www.alspr.com/>

Dong Guan XB Electronics Co., Ltd

Account Number: 705540238
 Bank Name: Citibank N. A., Hong Kong Branch
 Country/Region: Hong Kong
 Bank Code: 006
 Bank Address: 3 Garden Road, Central, Hong Kong
 SWIFT/BIC: CITIHKHX (CITIHKHXXXX*If 11 characters are required)

MAil: HK@ALPSR.CN XB@ALPSR.CN
 Quality core! Afterburner for Made in China!

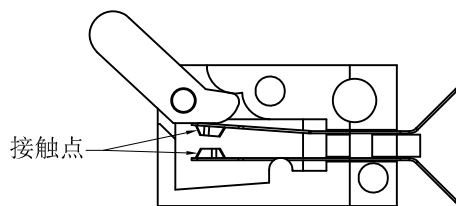
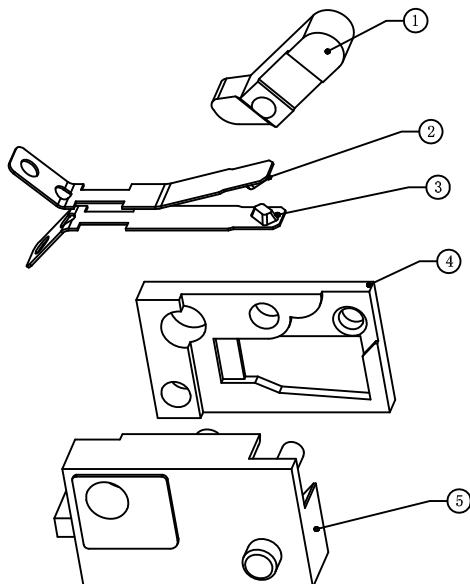
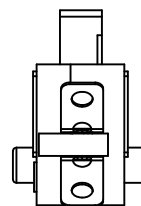
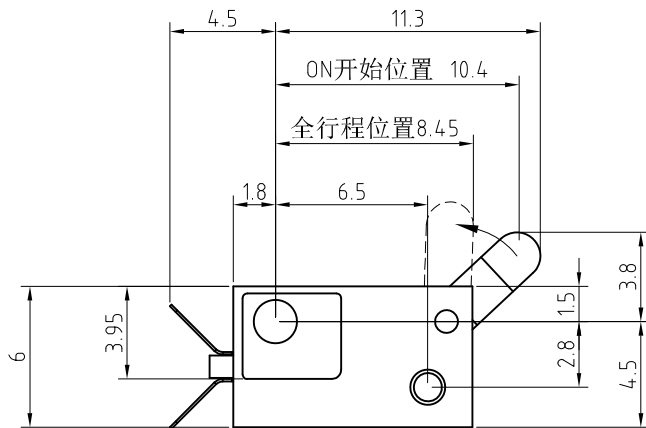

电路图：常开式(N.O)

5	基座		1	黄铜	绿色
4	盖子		1	PPA	绿色
3	通电弹片2		1	镀青铜	CU/EP·Ni Ag
2	通电弹片1		1	镀青铜	CU/EP·Ni Ag
1	按钮		1	POM	黑色
序号	名称	型号	数量	材料	备注

装订号

媒体位置

旧底图号

底图号

标记	处数	区分	更改文件号	签名	年月日
	签名	年月日		签名	年月日
设计	周石龙	16-11-6	标准化	周小琴	16-11-6
校对	周石龙	16-11-6	审核	杨建斌	16-11-6
工艺	王善凤	16-11-6	批准	杨建忠	16-11-6

材料详见上表

XB 东莞市溪榜电子有限公司
DONG GUAN XI BANG ELECTRONI CS CO., LTD.

检测开关

XB-TM-V-101A

物料编码:

阶段标记 重量 比例

S A B C free

共1张 第1张



东莞市溪榜电子有限公司
DONG GUAN XI BANG ELECTRONICS CO., LTD.

文件类型
TYPE OF FILE

规格书
SPECIFICATION

文件编号
FILE NO.

产品系列 SERIES	检测开关 Detector Switch	产品型号 TYPE	XB-TM-V-101A	页次 PAGE	1 of 4
发布日期 ISSUED DATE	2016-11-8	修正日期 AMENDED DATE		版本 VERSION	A

1、温度范围

Temperature range

1.1 使用温度范围： -10℃~+60℃（标准）-40℃~+85℃（车载）

Temperature range for use -10℃~+60℃（标准）-40℃~+85℃（车载）

2、测试环境条件：

Test circumstance condition:

环境温度： -25℃ ~85℃

Ambient temperature : -25℃ ~85℃

相对湿度： 45%~85%

Relative humidity : 45%~85%

空气压力： 102 千帕

Air pressure: 102KPa

3、外观、结构和尺寸

Appearance 、 structure and dimension

3.1 外观:

Appearance:

外观美观、没有生锈、伤痕、电镀不良、破裂，剥离现象。动作正常，换位清晰。

Nice appearance, free from rust, scar, bad plating, denude, normal action, clear conversion.

3.2 结构和尺寸:

Structure and Dimension:

参照有关外形图

Reference to the relative

4、额定值： 50 μ A 3V DC~10mA 16V DC(电阻负荷)

Rating: 50 μ A 3V DC~10mA 16V DC(电阻负荷)



东莞市溪榜电子有限公司
DONG GUAN XI BANG ELECTRONICS CO., LTD.

文件类型
TYPE OF FILE

规格书
SPECIFICATION

文件编号
FILE NO.

产品系列 SERIES	检测开关 Detector Switch	产品型号 TYPE	XB-TM-V-101A	页次 PAGE	2 of 4
发布日期 ISSUED DATE	2016-11-8	修正日期 AMENDED DATE		版本 VERSION	A
项目 Item	测试条件 Test Condition			规格 Performance	
5、机械性能 Mechanical Performance					
5.1	动作力 Operating Force	<p>开关垂直于操作方向放置，在按钮一侧逐渐施力，测量开关导通所需的最大力度。</p> <p>Vertical placing the switch with the direction of switch operation, then gradually increasing the force, measure demanded maximum force that switch continuity.</p>		0.4±0.2N	
5.2	端子强度 Terminal strength	<p>在端子的顶部施加一向内推的 10N 静负荷，持续 60 秒。</p> <p>Enforce push-inward static 25N load on the top of terminal, lasting 60 seconds</p>		<p>端子无损伤，脱落，开关功能动作正常。</p> <p>No damage, leafing, switch function action is normal.</p>	
5.3	可焊性试验 Solder-Ability	<p>将端子浸入熔融的锡槽内，温度为 235±5℃，时间为 3±0.5 秒。</p> <p>Immerse the terminal to the molten solder tank, temperature reach to 235±5℃,time reach to 3±0.5 seconds</p>		<p>浸入的部分 90%以上表面被锡覆盖。</p> <p>90% of the surface will be covered by solder.</p>	
5.4	耐焊性试验 Soldering resistance test	<p>端子的焊接部分浸入温度为 260±5℃熔融的锡炉内 3±0.5 秒。</p> <p>The welding part of terminal immerse molten solder at a temperature of 260±5℃ for 3±0.5 seconds.</p> <p>手工烙铁焊接：焊接温度 350±5℃，焊接时间 3±0.5 秒。焊接时在端子上不能施加异常压力。</p> <p>Manual iron welding: welding temperature: 350±5℃,welding time: 3±0.5 seconds. When welding, can't enforce anomaly pressure on the terminal.</p>		<p>本体无变形，能满足于机械、电气性能</p> <p>Without deformation of base, can satisfy mechanical, electronic performance.</p>	



东莞市溪榜电子有限公司
DONG GUAN XI BANG ELECTRONICS CO., LTD.

文件类型
TYPE OF FILE

规格书
SPECIFICATION

文件编号
FILE NO.

产品系列 SERIES	检测开关 Detector Switch	产品型号 TYPE	XB-TM-V-101A	页次 PAGE	3 of 4
发布日期 ISSUED DATE	2016-11-8	修正日期 AMENDED DATE		版本 VERSION	A1

项目 Item	测试条件 Test Condition	规格 Performance
5.5 动作位置	见成图	ON=4.7±0.3mm

6、电气性能 Electronic Performance

6.1	接触电阻 Contact resistance	在 1KHz 小电流下测量。 Being measured at 1KHz small current.	150mΩ 以下（初始）
6.2	绝缘电阻 Insulation resistance	在端子之间和端子与外壳之间施加 DC500V，一分钟后测量。 Measurement shall be made enforcing DC500V between terminals and between terminals and frame for 1 minute.	100 兆欧姆以上 100MΩ MIN.
6.3	耐电压 Withstand voltage	在极与极之间施加 AC100V, 0.5mA 1 分钟，在极与操动轴之间施加 AC150V, 0.5mA 1 分钟。 Enforce AC100V, 0.5mA between pole and pole in 1 minute ,enforce AC150V, 0.5mA between pole and frame in 1 minute.	无击穿现象出现。 No breakdown.

7、耐久性能 Durability

7.1	机械寿命 Mechanical life	每分钟 30 次的速度 50000 次 Operating 50000 cycles at a rate of 30cycles per minute	外观，动作功能正常
7.2	电气寿命 Electrical life	额定负载条件下,每分钟 30 次的速度操作 ≥ 1E4 次。 Operating ≥ 1E4 cycles at a rate of 30cycles per minute under rate loading on conaition	1.温升≤30K Temperature Raising ≤30K



东莞市溪榜电子有限公司
DONG GUAN XI BANG ELECTRONICS CO., LTD.

文件类型
TYPE OF FILE

规格书
SPECIFICATION

文件编号
FILE NO.

产品系列 SERIES	检测开关 Detector Switch	产品型号 TYPE	XB-TM-V-101A	页次 PAGE	4 of 4
发布日期 ISSUED DATE	2016-11-8	修正日期 AMENDED DATE		版本 VERSION	A1

项目 Item	测试条件 Test Condition	规格 Performance
------------	------------------------	-------------------

8、耐候性 Weather Ability

8.1	耐高温试验 Heat test	在 125±2℃环境中放置 72 小时，再放在正常环境中 60 分钟后进行测试。 Putting at 125±2℃ for 72 hours. Test after keeping in normal condition for 60 minutes.	1、接触电阻 50 毫欧以下 Contact resistance 50mΩ MAX. 2、绝缘电阻 100 兆欧以上 Insulation resistance 100MΩ MIN. 3、耐电压 100V, 0.5mA 1 分钟无击穿 Withstand voltage 100V,0.5mA,no breakdown. 4、无任何迹象显示机械及电气性能之损坏 No sign of damage mechanical and electronic performance.
8.2	耐湿试验 Anti-humid test	在温度为 40±2℃，相对湿度为 91%-95%RH 的环境中放置 96 小时，再放在正常环境中 60 分钟后进行测试。 Putting at 40±2℃, 91%~95%RH for 96 hours. Test after keeping in normal condition for 60 minutes.	
8.3	耐低温试验 Anti-low temperature test	在-25±3℃的环境中放置 16 小时，再放在正常环境中 60 分钟后进行测试。 Putting at -25±3℃ for 16 hours. Test after keeping in normal condition for 60 minutes.	
8.4	焊锡条件 Soldering conditions	Hand soldering 手焊： 1) Dvice 工具: Solder iron 电烙铁 A.270℃Max. , 2 sec Max B.230℃Max. , 4 sec Max 2) Reflow soldering 回流焊: ≤235℃	外观无异常，满足于机械，电气性能 There shall be no Damage on appearance. Mechanical and electrical Characteristics shall Be satisfied.