



规格书

SPECIFICATION

CUSTOMER NAME	客户名称:	_____
CUSTOMER NO.	客户编号:	_____
SERIES	系列:	5.08间距 排针连接器
MODEL NO.	型号:	XB-PZ SERIES
DRAWING NO.	图形号:	5.08 spacing row pin connector

If specification of this product meets your request, please confirm all the items of it and return to us with signature and stamp, it will be basis of our production and record. Thanks your cooperation in advance!

若此产品规格符合贵司要求, 敬请确认此规格书内所有项目
并签名和盖章后回传给我司, 以作我司产品制作之
依据和存档之用, 多谢合作!

EXAMINE & APPROVAL 审批

APPROVE 接受	NOT APPROVE 不接受
 SIGNATURE 签署 STAMP 盖章 DATE 日期	

PREPARED BY.制表人	CHECKED BY.校对	APPROVED BY.审核	APPROVAL BY. 批准
研发部 戴海明 2022.06.08	品质部 黄自清 2022.06.08	工程部 庞军 2022.06.08	总经理办 吴量 2022.06.08

东莞市溪榜电子有限公司

Dong guan Xi Bang Electronics Co., Ltd

地址: 广东省东莞市黄江镇合路工业区

Address: He Lu Industrial Zone, Huangjiang Town, Dongguan City, Guangdong Province

Tel: (0769)82055138/82056828

Fax: (0769)83663452

邮箱: admin@alspr.com switch@alspr.com

http://www.alspr.cn/ http://www.alspr.com/

Dong Guan XB Electronics Co., Ltd

Account Number: 705540238

Bank Name: Citibank N. A., Hong Kong Branch

Country/Region: Hong Kong

Bank Code: 006

Bank Address: 3 Garden Road, Central, Hong Kong

SWIFT/BIC: CITIHKHX (CITIHKHXXXX*If 11 characters are required)

MAil: HK@ALPSR.CN XB@ALPSR.CN

Quality core! Afterburner for Made in China!



东莞市溪榜电子有限公司
DONG GUAN XI BANG ELECTRONICS CO., LTD.

文件編號	PS-N07-0018
版次	A/0
頁次	1 / 7
制定部門	研發單位
公佈日期	2018年03月22日

類別	XB-PZ SERIES PRODUCT SPECIFICATION
PS	

文件變更履歷表

版次	制 / 修 / 廢原因		頁次	制 / 修 / 廢日期	
A/0	新增產品規範		全部	2018/03/22	
核 準	高 鵬	審 查	賀 龍 飛	制 定	賴 海 杰
日 期	2018/03/22	日 期	2018/03/22	日 期	2018/03/22



SERIES PRODUCT SPECIFICATION

FILE NO.

PS-N07-0018

PAGE:

2 / 7

DATE:

2018 / 03 / 22

REV.

A / 0

1.0 SCOPE (範圍) :

This specification covers the requirements for product performance and test methods of the XB-PZ Series connector. Product shall be of the design, construction and physical dimensions specified in the applicable product drawing. (本規格書涵蓋了XB-PZ Series連接器的產品性能要求和測試方法。產品應符合適用產品圖面中規定的設計、結構、尺寸等。)

2.0 APPLICABLE DOCUMENTS (適用文件) :

The following document, of the latest issue in effect at the time of performance of the qualification tests, shall form a part of this specification to the extent specified herewith. (本版本中以下文件，在性能鑒定試驗時生效，將構成本規範的一部分。)

EIA-364 Test methods for electrical connectors. (EIA-364 電器連接器的測試方法)

3.0 PRODUCT DESCRIPTION AND PART NUMBER (產品描述和型號) :

Product description (產品描述)	Part No. (型號)
PITCH 5.08mm MALE CONNECTOR	XB-PZ SERIES

4.0 PROPERTY (特性) :

4.1 Ratings (額定值) :

4.1.1 Current Rating (額定電流) : 7.9A (AC / DC) Per contact.

4.1.2 Voltage Rating (額定電壓) : 250V AC/DC.

4.1.3 Operating Temperature Range (工作溫度) : -40°C~105°C.

4.1.4 Operating Humidity (工作濕度) : 85% Max.

4.2 Materials (材料) :

4.2.1 Housing (塑殼) : LCP, Nylon 6T, PBT, Nylon 9T, Nylon 66 or Nylon 46, flame retardant 94V-0 per UL-94; or other high performance resin.

4.2.2 Contact (端子) : Brass, Phosphor Bronze or other equivalent copper alloys.

Finish (表面處理) : See plating drawing.

4.2.3 Harmful Material Should Be Compliant to XI BANG Standards (Per QPNQ0817).

有害物質應符合溪榜公司的標準(參考文件QPNQ0817)。

5.0 TEST CONDITION (測試條件) :

5.1 Temperature range (溫度範圍) : 20°C to 30°C.

5.2 Humidity range (濕度範圍) : 30% RH to 70%RH.

6.0 STORAGE CONDITION (儲藏條件) :

6.1 Temperature range (溫度範圍) : 5°C~30°C.

6.2 Humidity range (濕度條件) : ≤65%.

6.3 Shelf life (存儲期限) : 1 Year.



7.0 TEST METHODS AND REQUIREMENTS (測試方法和要求) :

7.1 GENERAL EXAM (一般測試) :

Test item (測試項目)	Test procedure (測試流程)	Condition of test specimens (測試狀態)	Requirement (要求)
1 Examination of Product (產品檢查)	Per EIA-364-18 Visual and functional inspection. (依照 EIA-364-18 外觀和功能性檢查)		Meet requirements of product drawing. No evidence of physical damage (符合圖面要求,無物理損傷)

7.2 ELECTRICAL PERFORMANCE (電氣性能) :

Test item (測試項目)	Test procedure (測試流程)	Condition of test specimens (測試 狀態)	Requirement (要求)
1 Low level contact resistance (低階接觸阻 抗)	Per EIA-364-23 Subject mated connector with a max. voltage of 20mV and current of 100mA. (依照EIA-364-23 在配對連接器上施加最大20mV電壓和100mA電流。)	Mating (配對)	Initial = 30mΩ Max. Final = 50mΩ Max.
2 Dielectric Withstanding Voltage (耐电压)	Per EIA-364-20 Subject mated connector with a. voltage of 1000V AC for 1 minute between adjacent terminals. (依照EIA-364-20 在配對好的連接器的相鄰兩個端子上接通1000V的交流電,持續1分鐘。)	Mating (配對)	No Breakdown. Leakage Current: 5mA Max. (無擊 穿,漏電電流:5mA 最大)
3 Insulation Resistance (絕緣阻抗)	Per EIA-364-21 Subject mated connector with a. voltage of 500V DC between adjacent terminals. (依照 EIA-364-21, 在配對好的連接器的相鄰兩個端子上接通 500V 的直流電。)		1000MΩ Min.



7.3 MECHANICAL PERFORMANCE (機械性能測試) :

Test item (測試項目)	Test procedure (測試流程)	Condition of test specimens (測試狀態)	Requirement (要求)
1 Contact Retention Force (保持力)	Per EIA-364-37 The end of a post shall be pulled in a perpendicular to base housing at a constant speed of 25.4mm/ minute. (依照 EIA-364-37, 垂直與基殼方向上以 25.4mm/minute 恒定的測試速度拉端子末端。)		Gold plating= 9.8N Min. per pin. Tin plating= 12N Min. per pin. (鍍金 9.8N/PIN, 鍍錫 12N/PIN)
2 Durability (耐久度)	Per EIA-364-09 Perform 100 cycle Mating/unmating at a rate of 25.4mm/ minute. (依照 EIA-364-09以25.4mm/ minute勻速速度循環插拔100次。)		No evidence of physical damage 無物理損傷現象

7.4 ENVIRONMENTAL PERFORMANCE (環境性能) :

Test item (測試項目)	Test procedure (測試流程)	Condition of test specimens (測試狀態)	Requirement (要求)
1 Thermal Shock (冷熱衝擊)	Per EIA-364-32, Mated connectors: expose to 5cycles of: (依照EIA-364-32,執行如下條件的5次循環) Temperature ^{°C} Duration(Minutes) 溫度 持續時間(分) -40 ^{°C} +0/-5 30 Min. +25 ^{°C} +10/-5 5 Max. +105 ^{°C} +3/-0 30 Min. +25 ^{°C} +10/-5 5 Max.		No evidence of physical damage 無物理損傷現象
2 Temperature life(高溫壽命測試)	Per EIA-364-17 Test Condition: 105 ^{°C} , 96hours. (依照EIA-364-17,測試條件: 105 ^{°C} , 96小時。)		No evidence of physical damage 無物理損傷現象
3 Humidity Test(濕度測試)	Per EIA-364-31 Test Condition: 40±2 ^{°C} , 90-95% RH, 96 hrs. (依照 EIA-364-31, 測試條件: 40±2 ^{°C} , 90-95% RH,96 小時。)		No evidence of physical damage 無物理損傷現象



SERIES PRODUCT
SPECIFICATION

FILE NO.

PS-N07-0018

PAGE:

5 / 7

DATE:

2018 / 03 / 22

REV.

A / 0

4	Salt Spray (鹽霧)	Per EIA-364-26 Test Condition: Temperature: $35\pm 2^{\circ}\text{C}$; Atmosphere: 5% salt-solution. Duration: 16 hours exposure for gold area; 8 hours exposure for tin area. (依照 EIA-364-26 測試條件： $35\pm 2^{\circ}\text{C}$ ， 錫區域：8 小時；金區域：16 小時，5% 鹽 溶液。)		No evidence of physical damage 無物理損傷現象
5	Solder ability Test (可焊性測 試)	Per EIA-364-71 Test Temperature: $245\pm 3^{\circ}\text{C}$ ， 3~5sec. (依照EIA-364-71 測試溫度： $245\pm 3^{\circ}\text{C}$ ， 3~5秒)		After exposure, the contact solder tails shall have a minimum of 95% solder coverage. (風乾後，端子 焊錫覆蓋率至少 95%。)
6	Resistance to Soldering Heat (焊接耐熱 性)	Per EIA- 364- 56 Soldering iron method Solder Temp.: $380\pm 10^{\circ}\text{C}$ /3~5 seconds. Reflow(Only suitable for the materials with high temperature resistance.): Please see recommended profile. Pre Heat: $150^{\circ}\text{C}\sim 200^{\circ}\text{C}$ /60 to 120 seconds Heat: 217°C ;60-150 seconds Peak Temp.: $260\pm 5^{\circ}\text{C}$ /5~15 seconds. (依照EIA-364-56，手工焊接溫度： $380\pm 10^{\circ}\text{C}$ /3~5秒，回流焊(適用於耐高溫材 料)：預加熱： $150^{\circ}\text{C}\sim 200^{\circ}\text{C}$ /60-120 秒；加熱： 217°C ;60-150 秒；最高溫度： $260\pm 5^{\circ}\text{C}$ /5~15 秒)		No evidence of physical damage 無物理損傷現象

8.0 INFRARED REFLOW CONDITION (LEAD-FREE)(紅外回流焊條件(無鉛)):

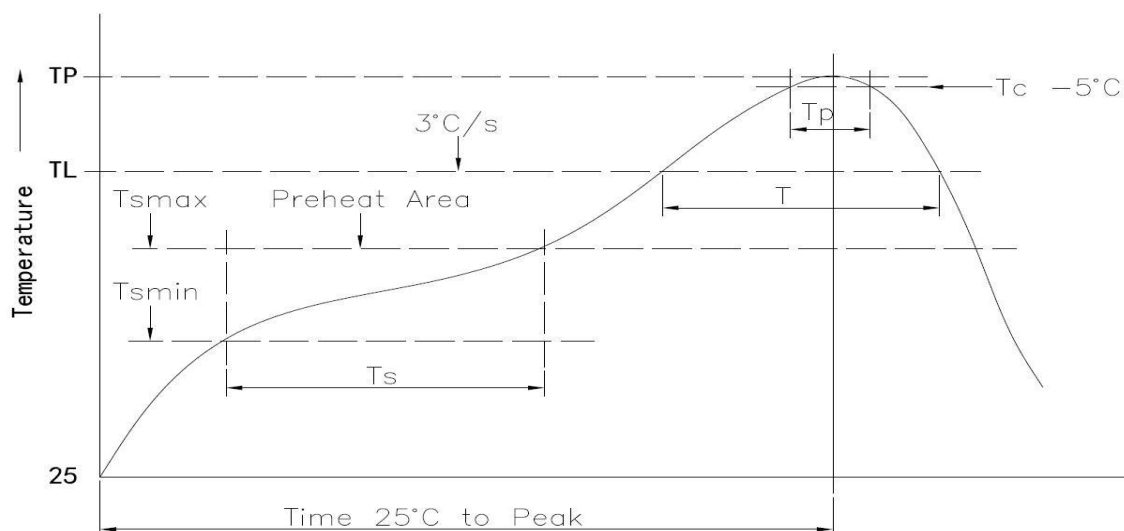

Profile Feature (特性)	Pb-Free Assembly (無鉛組裝)
Preheat & Soak (預熱&浸泡) Temperature min (T Amin) (最低溫度) Temperature max (T smax) (最高溫度) Time (T Amin to T smax) (ts) (時間)	150°C ~ 200°C / 60 to 120 seconds
Average ramp-up rate (T smax to T p) (平均溫升率)	3 °C/second max.
Liquidous temperature (TL) (液化溫度) Time at liquidous (tL) (液化時間)	217 °C 60-150 seconds
Peak package body temperature (T p)* (封裝最高溫度)	260±5°C / 5~15 seconds
Time (t p)** within 5 °C of the specified classification temperature (T c) (在指定等級溫度5°C內的時間)	20~40seconds
Average ramp-down rate (T p to T smax) (平均溫度下降速率)	6 °C/second max.
Time 25 °C to peak temperature (25 °C至峰值溫度的時間)	8 minutes max.

(a) Per IPC/JEDECJ-SID-020 Clause 5.6. (依照 IPC/JEDECJ-SID-020 中 5.6 小節.)

(b) Test Condition: Test connector shall be placed on the p.c. board.

(測試條件：須在 PCB 板上測試連接器。)

(c) Temperature condition graph: Temperature on board pattern side.



SERIES PRODUCT
SPECIFICATION

FILE NO.

PS-N07-0018

PAGE:

7 / 7

DATE:

2018 / 03 / 22

REV.

A / 0

(溫度條件曲線圖：在板子圖案面的溫度。)

(d) Thickness of steel mesh: 0.15mm Min. (鋼網厚度：最小 0.15mm.)

(e) Lead-free Process : DURATION = 2 TIMES. (無鉛製程：持續=2 回。)

9.0 PRODUCT QUALIFICATION AND TEST SEQUENCE (產品認證和測試序列) :

Test Item	A	B	C	D	E	F	G	H
Sample Size	3	3	3	3	5	3	3	3
Examination of Product (產品檢查)	1,5	1,5	1,9	1,7	1,5	1	1,3	1,3
Low level contact resistance (低階接觸阻抗)	2,4	2,4	2,8		2,4			
Insulation Resistance (絕緣阻抗)			3,7	2,5				
Dielectric Withstanding Voltage (耐電壓)			4,6	3,6				
Temperature Life (高溫壽命)		3						
Humidity Test (溫度測試)				4				
Thermal shock (冷熱衝擊)	3							
Solder ability (可焊性)								2
Resistance to Soldering Heat (焊接耐熱性)							2	
Contact Retention Force (保持力)						2		
Durability (耐久)					3			
Salt Spray (鹽霧)			5					