

SYMB	REVISION	DATE	APVD.

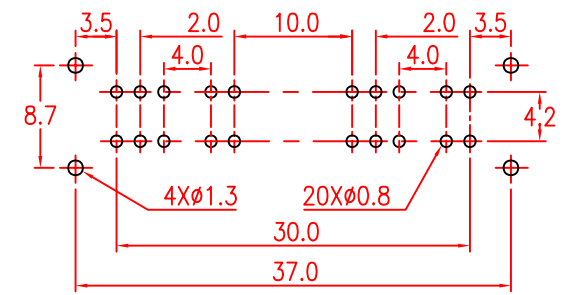

P.C.B LAYOUT
TOP VIEW

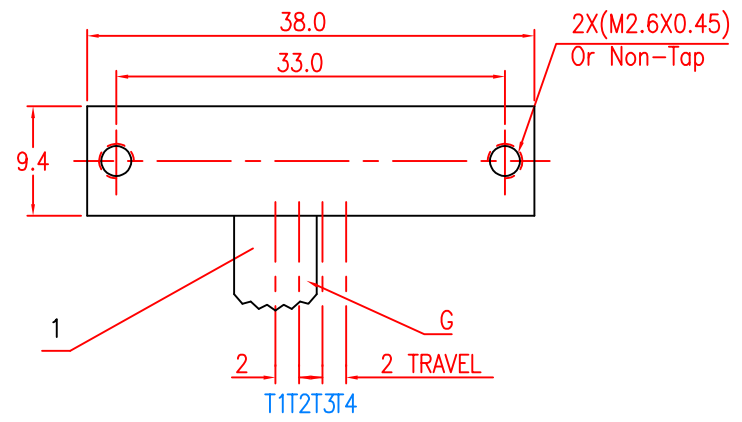
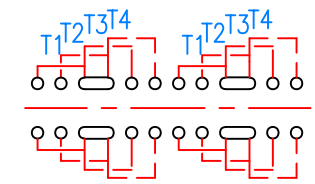
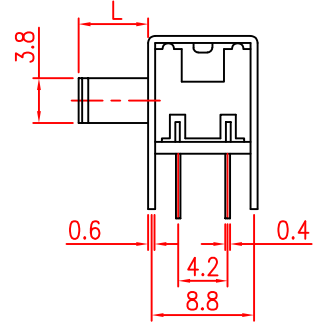
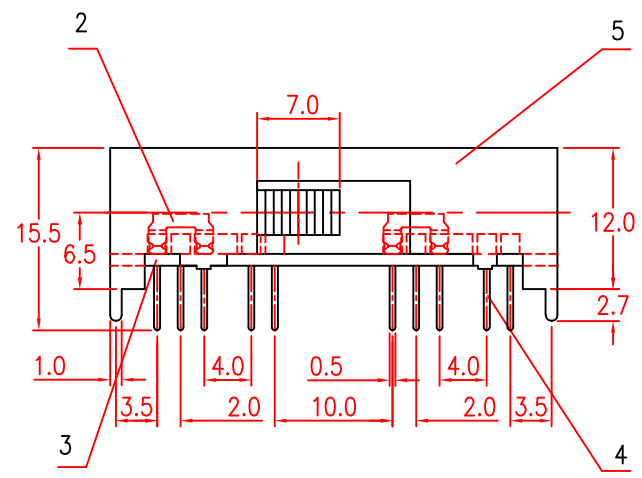

CIRCUIT

L=15.0mm

TITLE	SLIDE SWITCH	DRAWN	TOLERANCE OTHERWISE UNLESS SPECIFIED	8								
PART NO.	XB-SK-44D01	CHECKED	UP TO 5	± 0.2	6							
DRAW NO.	K54	APPROVED	ABOVE 5 ~ 30	± 0.3	5	FRAME	SPCC	1 Ni PLATED				
SCALE	3:2	UNIT	mm	DATE	20-01-2005	ABOVE 30 ~ 50	± 0.4	4	TERMINAL	BRASS STRIP	20	Ag PLATED
						ABOVE 50	± 0.5	3	BASE	PHENOLIC RESIN	1	NATURAL
						ANGLE	$\pm 3'$	2	CONTACT PLATE	PBS	4	Ag PLATED
						1	KNOB	POM	1	BLACK		
						NO.	PARTS	MATERIAL	QTY.	FINISHING		

