

REV.	EC#	DESCRIPTION	DATE	DRAWING	CHECKED	APPROVED
A		NEW RELEASE	09/28'13	HAIYONG	——	HAIYONG
A1		更改包装方式(增加护角, 珍珠棉, 更改纸箱规格)	02/24'14	HAIYONG		HAIYONG

A
B
C
D
E

A
B
C
D
E

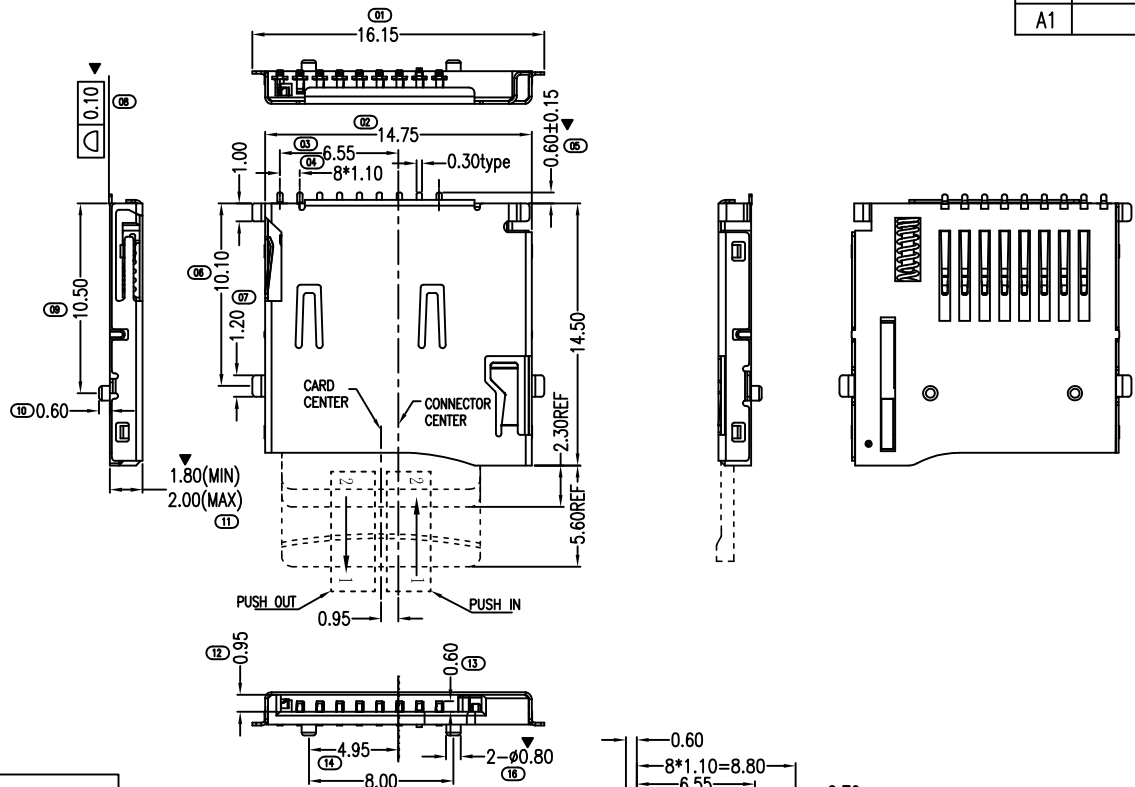

NOTES:
 ELECTRICAL CHARACTERISTICS
 CONTACT CURRENT RATING:0.5A
 DIELECTRIC WITHSTANDING VOLTAGE:AC 500V
 INSULATION RESISTANCE:500MΩ MIN
 CONTACT RESISTANCE:100mΩ MAX
 ENVIRONMENTAL
 TEMPERATRUE RANGE: -25°C TO +85°C
 MECHANICAL CHARACTERISTICS
 MATING CYELES:5000 INSERTIONS
 INSERTION/OUT FORCE:0.1-4.0KGF
 MATERIAL
 HOUSING: HIGH TEMPERATURE PLASTIC UL94V-0 (LCP)
 COLOR:BLACK
 SLIDER:HIGH TEMPERATURE PLASTIC UL94V-0 (LCP)
 COLOR:BLACK
 CONTACT: COPPER ALLOY(C5191)
 SHELL: STAINLESS (SUS304)
 SPRING:SWP-B
 SNAP:STAINLESS (SUS304)
 PLATING:
 CONTACT
 UNDERPLATE: NICKEL 30-60u".
 CONTACT AREA: GOLD FLASH OVER NICKEL 30-60u".
 SOLDER AREA: TIN 80u" MIN OVER NICKEL 30-60u".
 SHELL:PLATE 30u"NICKEL MIN (Test Point For SMT Foot)

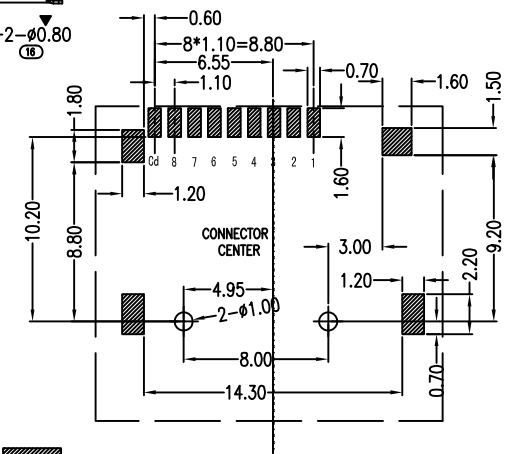
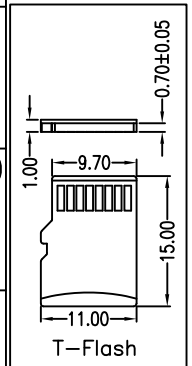

RECOMMENDED P.C.B HOLE LAYOUT
 COMPONENT SIDE VIEW(TOLERANCE: +/-0.05)

PIN NO.	NAME	YYPE	DESCRIPTION
1	DAT2	I/O/PP	DATE LINE(BIT2)
2	CD/DAT3	I/O/PP	CARD DETECT DATE LIN(BIT3)
3	CMD	PP	COMMAND RESPONSE
4	VDD	S	SUPPLY VOLTAGE
5	CLX	I	CLOCK
6	VSS	S	SUPPLY VOLTAGE GROUND
7	DATO	I/O/PP	DATE LINE(BIT0)
8	DAT1	I/O/PP	DATE LINE(DIT1)

T-F铁壳	1PC
T-F线簧	1PC
T-F弹簧	1PC
T-F 9PIN端子	1SET
T-F滑块	1PC
T-F主体胶芯	1PC
规格	数量

MILLIMETERS	INCH	UNITS	MM
X° ± 2°	X° ±	MAT'L	
.X ± 0.35	.XX ±	SEE NOTES	
.XX ± 0.25	.XXX ±	FINISH	
.XXX± 0.15	.XXXX±	SEE NOTES	
		QTY	
		SEE NOTES	

XB 东莞市溪榜电子有限公司
 DONG GUAN XI BANG ELECTRONI CS CO., LTD.

PART NUMBER: XB-102010862 TITLE: T-FLASH 外焊卡座(带双弹片)

APPD: HaiYong DWG NO.: C-102010862-00

CHKD: --- DR: YZZ

SCALE: 1:1 SHEET: 1/2 REV: A1

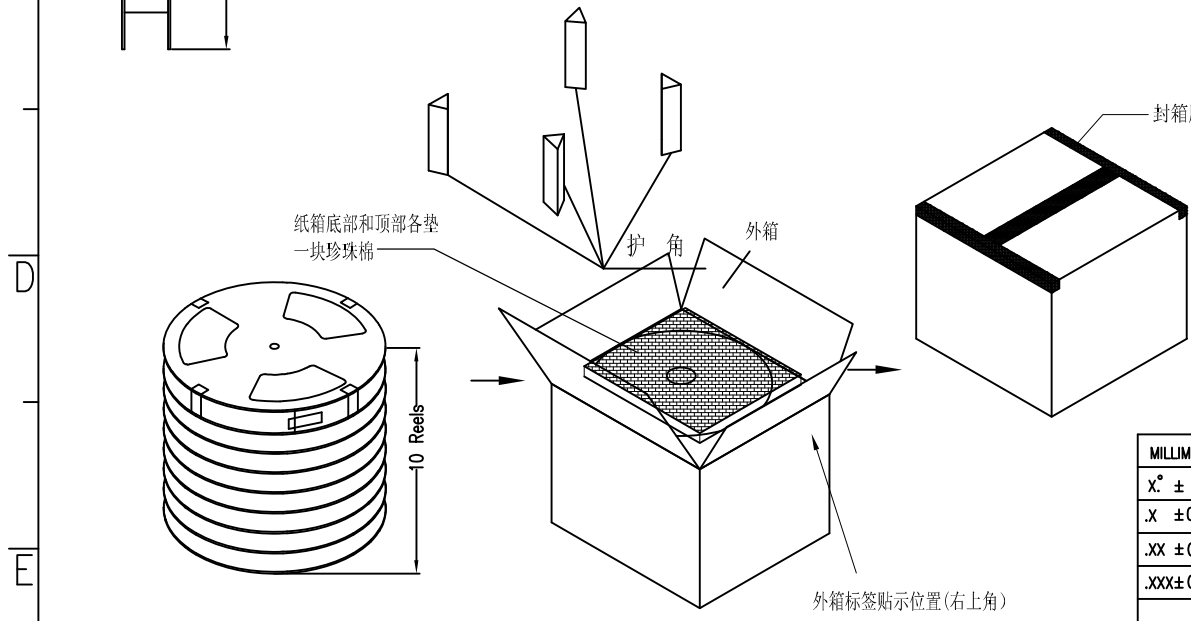
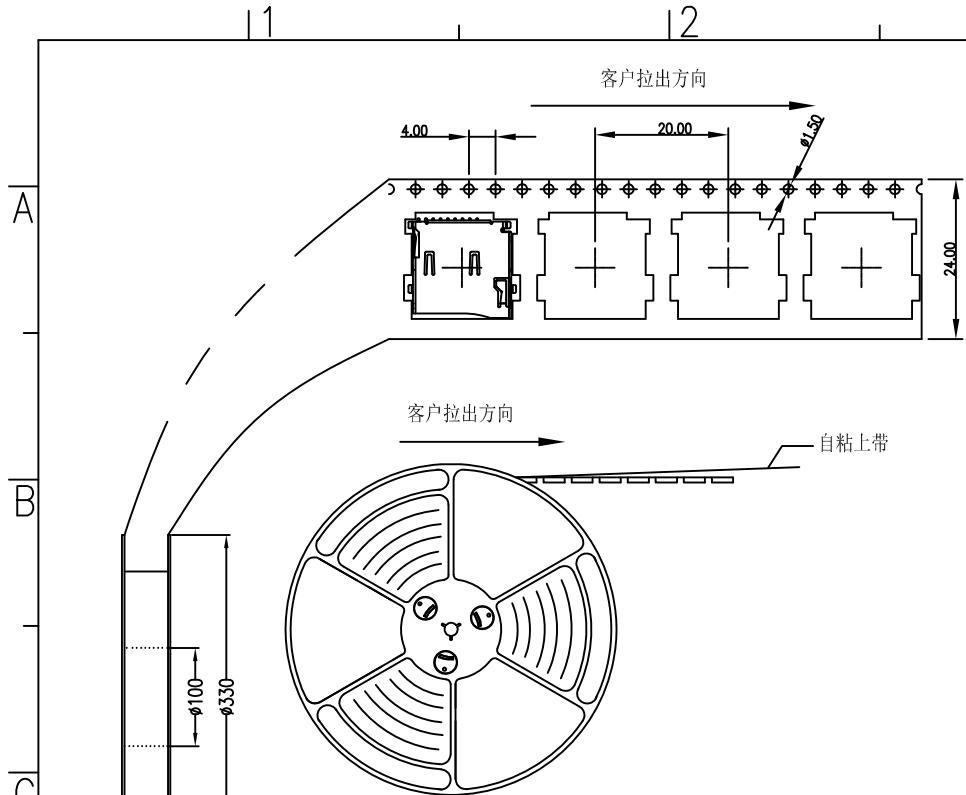

将10卷产品放入箱内

REV.	EC#	DESCRIPTION	DATE	DRAWING	CHECKED	APPROVED
A		NEW RELEASE	09/28'13	HAIYONG	——	HAIYONG
A1		更改包装方式(增加护角,珍珠棉,更改纸箱规格)	02/24'14	HAIYONG		HAIYONG

NOTES

- 1.每卷包装数量:1000PCS/每卷
- 2.卷带包装方式:

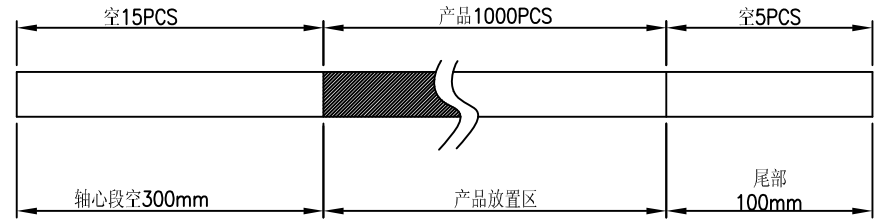

3.每箱包装数量:10000PCS/箱

4.纸箱350mm*350mm*340mm(内部尺寸),材质K=K

MILLIMETERS	INCH	UNITS	MM							
X° ± 2'	X° ±	MAT'L	东莞市溪榜电子有限公司 DONG GUAN XI BANG ELECTRONICS CO., LTD.							
.X ± 0.35	.XX ±	SEE NOTES								
.XX ± 0.25	.XXX ±	FINISH	PART NUMBER:	TITLE:						
.XXX ± 0.15	.XXXX ±	SEE NOTES	XB-102010862.	T-FLASH 外焊卡座(带双弹片)						
		QTY	APPD: HaiYong	DWG NO.:						
		SEE NOTES	CHKD: ---	C-102010862-00						
			DR: YZZ	<table border="1"> <tr> <th>SCALE</th> <th>SHEET</th> <th>REV.</th> </tr> <tr> <td>1:1</td> <td>1/2</td> <td>A1</td> </tr> </table>	SCALE	SHEET	REV.	1:1	1/2	A1
SCALE	SHEET	REV.								
1:1	1/2	A1								