

REVISION

A

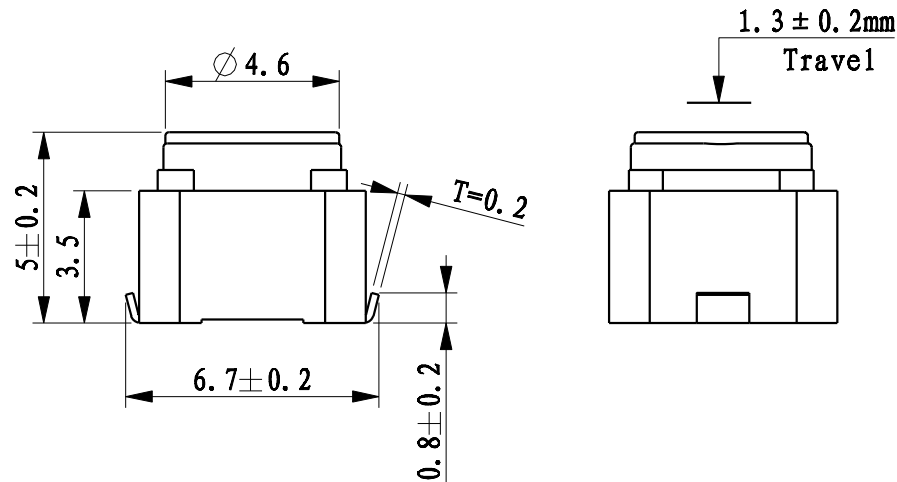

P. C. B LAYOUT

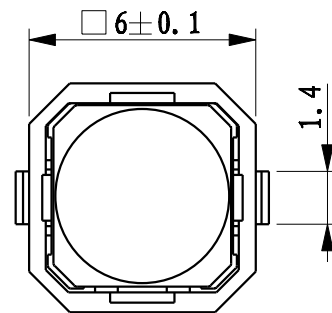
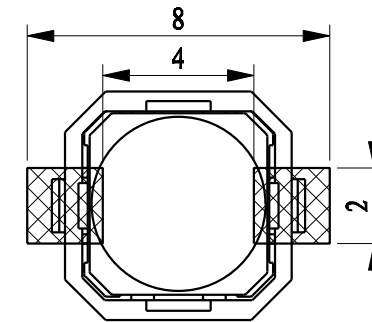

CIRCUIT

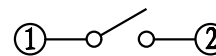

技术参数

1. 额定电流: 50mA 12VDC
2. 接触电阻: 100mΩ
3. 按 力: 260 ± 50gf
4. 行 程: 1.3 ± 0.2mm
5. 绝缘电阻: 100MΩ
6. 抗电强度: 100v 50Hz 1Min
7. 寿 命: 100,000 次

| | | | | | | | | | | | |
|--|------|-------------|----|----------|--|--------------------------------------|--|-------|-------|----------|-----|
| TITLE | | TACT SWITCH | | DRAWN | | TOLERANCE OTHERWISE UNLESS SPECIFIED | | | | | |
| PRODUCT NO. | | XB-TS-1199U | | CHECKED | | TOLERANCE | | ± 0.2 | | | |
| DRAWING NO. | | | | APPROVED | | ANGLE TOL | | ± 1° | | | |
| SCALE | 5: 1 | UNIT | mm | DATE | | | | | | | |
| 东莞市溪榜电子有限公司 DONG GUAN XI BANG ELECTRONICS CO., LTD. | | | | | | | | NO. | PARTS | MATERIAL | QTY |
| | | | | | | | | | | | |