

CAD FILE:

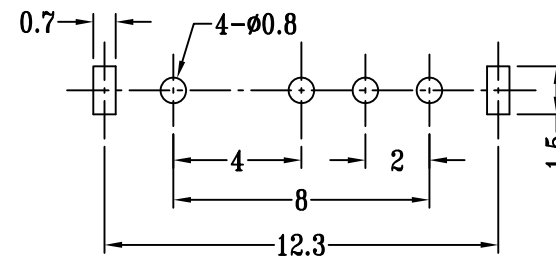

P.C.B LAYOUT
BOTTOM VIEW

注: "*"表示关键尺寸(5个).

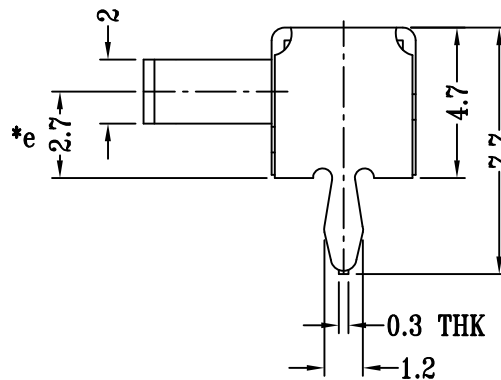
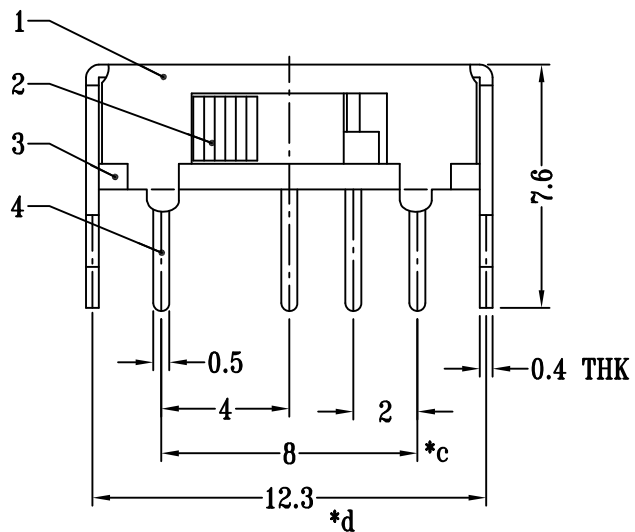
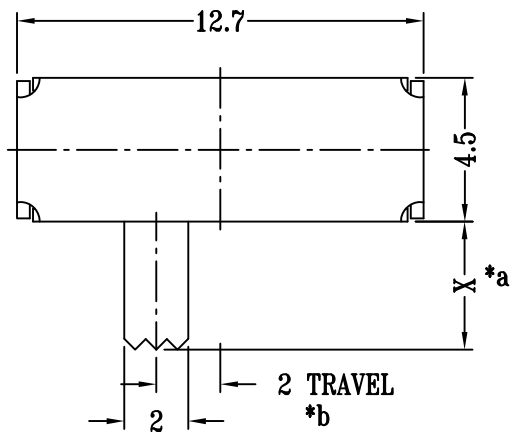
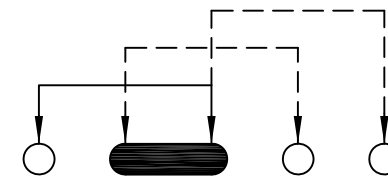

SCHEMATIC (No-SHORTING)

NO.	PARTS	MATERIALS	Q'TY	FINISH	TOLERANCE UNLESS SPECIFIED	DATE	DESCRIPTIONS OF REVISION	APPD.
8								
7								
6	SPRING PLATE	SUS	1	NATURAL	WITHIN 1.5mm : ±0.1mm	A	初版	曾鹏
5	CONTACT CLIP	PBS STRIP	1	Ag CLAD	OVER 1.5mm : ±0.2mm	ISSUE	DATE	APPD.
4	TERMINAL	BRASS STRIP	4	Ag PLATED	TITLE : HORIZONTAL SLIDE SWITCH		UNIT : mm	DRWG NO.: XB-SK-13D13
3	BASE	PHENOLIC RESIN	1	NATURAL	MODEL: XB-SK-13D13		SCALE: 4:1	DWN. 吴开庆 2012-8-8
2	KNOB	NYLON+F.G	1	BLACK	东莞市溪榜电子有限公司 DONG GUAN XI BANG ELECTRONI CS CO., LTD.		CHK'D 劳庆先	2012-8-8
1	FRAME	STEEL STRIP	1	Ni PLATED			APPD. 曾鹏	2012-8-8