

RoHS  
Compliant

ZONE	SYMBOL	REVISION	APPROVAL	DATE
A		L S J	W J Z	2022.04.26

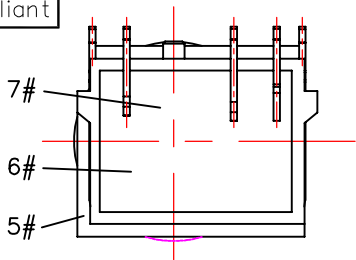

Notes:

- 1.Current Rating: 24V&5A max.
- 2.Contact Resistance: 50mOhms Max.(initial)
- 3.Insulation Resistance: 100M Ohms Min./500V DC
- 4.Dielectric Withstanding Voltage: 500V AC/1Minute
- 5.Mating Force: 35N Max, Withdrawal Force: 3N Min.
- 6.Durability: 5,000 Cycles
- 7.Operating Temperature:-25°C to+85°C

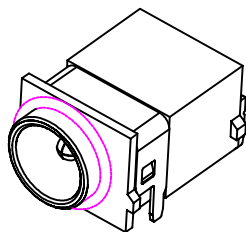
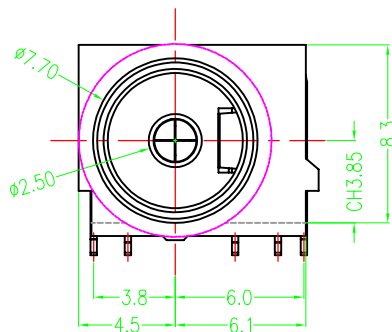
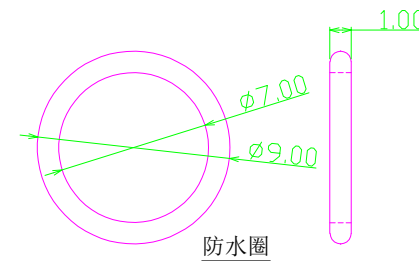
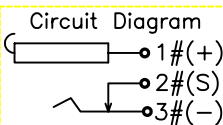
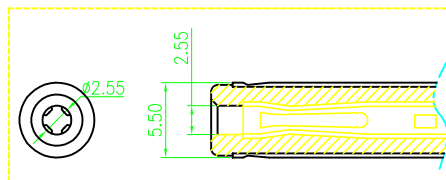
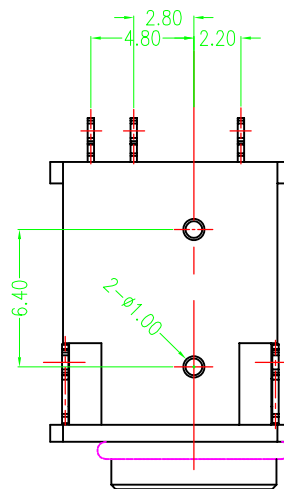
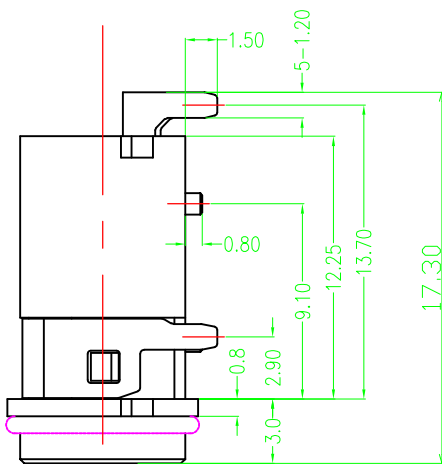
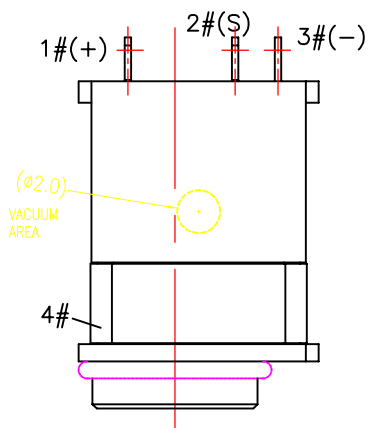
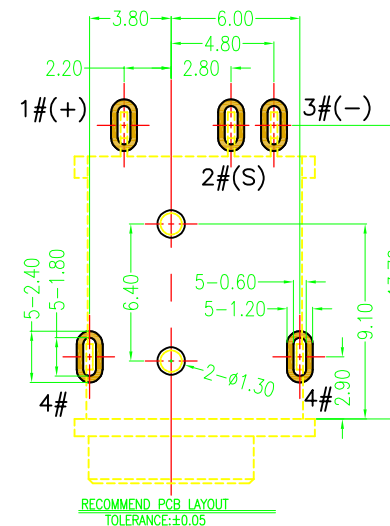
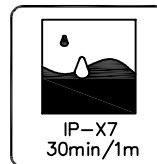

ITEM	NAME	Q'TY	DESCRIPTION	NOTE
8	WATERPROOF RING	1	SILICONE; WHITE	
7	GLUE	1	EPOXY; WHITE	
6	BACK COVER	1	HIGH TEMPERATURE; BLACK	
5	HOUSING	1	HIGH TEMPERATURE; BLACK	
4	TERMINAL 4#	1	STAINLESS STEEL; NICKEL PLATING	
3	TERMINAL 3#	1	COPPER ALLOY; NICKEL UNDER PLATING OVERALL, Au PLATING ON SOLDER AREA	
2	TERMINAL 2#	1	COPPER ALLOY; NICKEL UNDER PLATING OVERALL, Au PLATING ON THE WHOLE	
1	CENTER PIN	1	COPPER ALLOY; NICKEL UNDER PLATING OVERALL, Au PLATING ON SOLDER AREA	

**XB** 东莞市溪榜电子有限公司  
DONG GUAN XI BANG ELECTRONICS CO., LTD.

DRAWING:	X B	DATE:	2022.04.26	SCALE	5:1
CHECK:	X S J	DATE:	2022.04.26	MATERIAL	*
APPROVAL:	W J Z	DATE:	2022.04.26	DWG. no.	
DRAWING NO.	XB-30006-05DBAP-A			SHEET	

PART NAME		TOLERANCE UNLESS	0.0±0.2	UNIT:	mm
PART NO.	XB-30006-05DBAP-A	OTHERWISE SPECIFIED:	0.00±0.1 0.000±0.05		