

ROHS

|           |                 |                        |                       |            |            |
|-----------|-----------------|------------------------|-----------------------|------------|------------|
| 版本<br>REV | 修正标记<br>REV.LTR | 修正前<br>BEFORE REVISION | 修正后<br>AFTER REVISION | 签名<br>SIGN | 日期<br>DATE |
| V1.0      |                 | 新版制定                   |                       | June       | 20180929   |
|           |                 |                        |                       |            |            |
|           |                 |                        |                       |            |            |

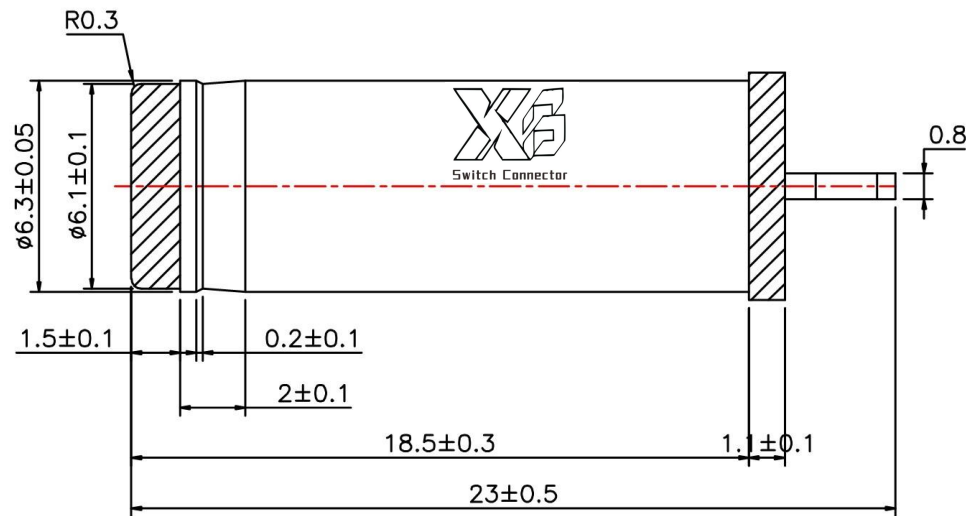
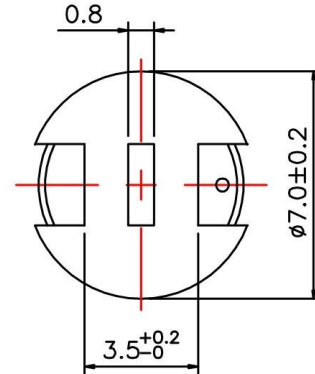
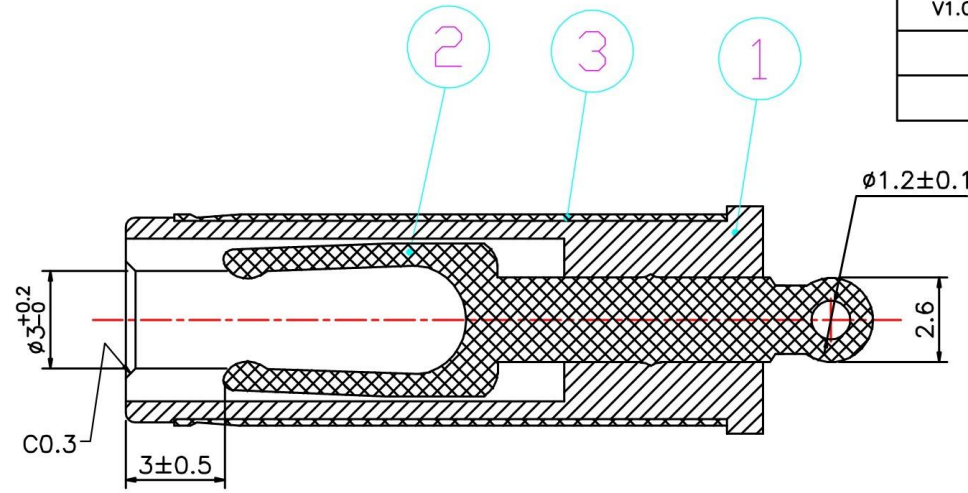
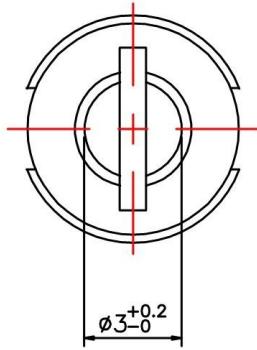

Technology Request:

- 1.Outlook:No burr, no hurt.
- 2.Electronic performance:
  - a:Insulation resistance: Above DC500V/100MΩ;
  - b:Endure voltage:AC500V at 1 minute;
  - c>Contact resistance:Under 30mΩ;
- 3.Insertion force & withdrawal force:0.3-3kgf.
- 4.Salt spray test:48H.
- 5.Meet RoHS.
- 6.Remark \* is important specification.

|                              |     |                               |   |
|------------------------------|-----|-------------------------------|---|
| 单位<br>Unit                   | mm  | 一般公差<br>The general tolerance | 7 |
| 比例<br>Scale                  | 5:1 | xx.:±0.3                      | 6 |
| 视图<br>Third angle projection |     | x.x.:±0.1                     | 5 |
|                              |     | .xx.:±0.05                    | 4 |

|     |                 |          |          |
|-----|-----------------|----------|----------|
| NO. | PART            | MATERIAL | PLATING  |
| 1   | PLASTIC         | PBT      | BLACK    |
| 2   | 6330*20*4.7音叉片  | C5191    | Ni 1~3um |
| 3   | 6.28*17*0.16车沟管 | H65      | Ni 1~3um |

|                   |                  |                |
|-------------------|------------------|----------------|
| 核准<br>APPROVED BY | 校对<br>CHECKED BY | 制图<br>DRAWN BY |
| June              | 杨义邦              | 苏伟伦            |

|   |                    |
|---|--------------------|
| <b>东莞市溪榜电子有限公司</b><br>DONG GUAN XI BANG ELECTRONICS CO., LTD. |                    |
| 规格<br>DESCRIPTION:  | DC PLUG 6.3*3.0*23 |
| 品名<br>P/N:  | XB-6330TV230       |
| 图号<br>DRAWN NO:   |                    |