

DS037-00P-60

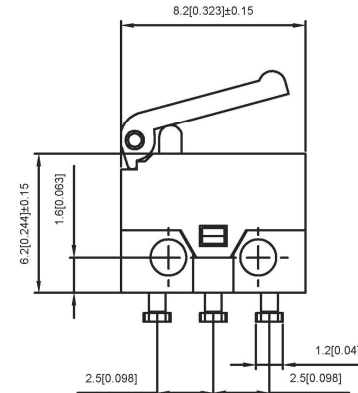

DS037-01D-30-C

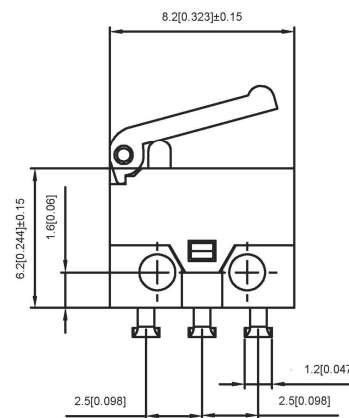

DS037-01C-30-C

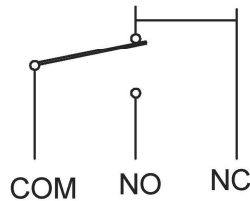
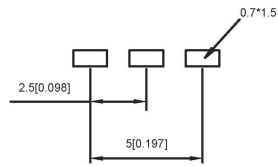

1.Functional spec	
1.1 Rated Voltage	0.3A@DC6V
1.2 Contact Resistance	≤50mΩ (Initial value)
1.3 Operating Force	
1.4 Free Position	
1.5 Operating Position	
2.Reliable Rating	
2.1 Mechanical Life	100,00 cycles
2.2 Electrical Life	50,000 cycles
2.3 Insulation Resistance	>100M Ω DC100V
2.4 Withstand Voltage	AC250V 1 minute
2.5 Soldering Temper	250℃ Max 3 Sec
2.6 Operating Temper	-25℃~+85℃
2.7 Ambient Humidity Used	<85%RH

				ANGULAR	±5°
				L ≤ 4	±0.2
				4 < L ≤ 16	±0.3
				16 < L ≤ 63	±0.4
				L > 63	±0.5
	DATE	REVISED	APPROVED	UNSPECIFIED TOLERANCES	



DSND		SCALE: N/A	MODEL TYPE:
DWN		VIEW:	The micro switch
CHKD		UNIT: mm/in	PART NO.:
APPD		SIZE: A4	DWG NO.: DS037-XXX-XXX
		WEIGHT	SHEET
			REVIS
		1/1	A0