

SCHEMATIC

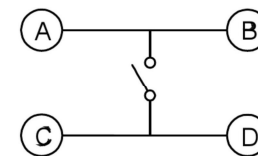

SPECIFICATION

Contact Rating: 50mA, 12V DC  
 Contact Resistance: 100mΩ max  
 Insulation Resistance: 100mΩ min. 500V DC  
 Dielectric Strength: 250V AC/1minute  
 Travel: 0.25mm  
 Operating Temp: -30°C~+85°C  
 Storage Temp: -30°C~+80°C

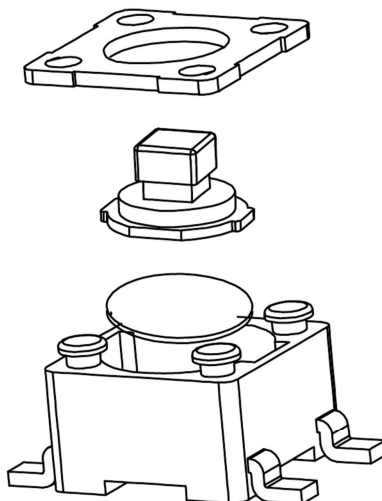
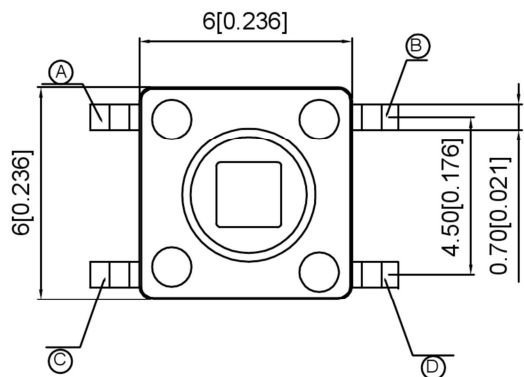

PAPT NO	TS-1102T-X
Operating Force	A:100gf B:160gf C:260gf
Height	D:7.3

Recommended P.C.B layout

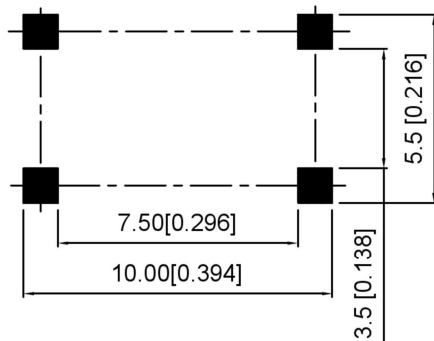

ITEM	PAPT NAMF	TER.NO	QTY	MATERIAL	FINISHING	REMARK
⑤	Terminal	---	4	Brass (0.30t)	Plating silvering	---
④	Contact	---	1	F.ag/Sus	Natural	---
③	Base	---	1	Pa46	---	---
②	Cover	---	1	Spcc	Plating Nickel	---
①	Keystake	---	1	Pa46	---	---

DSND		SCALE: N/A	MODEL TYPE: TACT SWITCH
DWN		VIEW:	PART NO.: TS-1102T-X
CHKD		UNIT: mm/in	DWG NO.:
APPD		SIZE: A4	
		WEIGHT	SHEET
			REVISI
		1/1	A0

ANGLAR	±5°
L ≤ 4	±0.2
4 < L ≤ 16	±0.3
16 < L ≤ 63	±0.4
L > 63	±0.5
UNSPECIFIED TOLERANCES	



DONG GUAN XI BANG ELECTRONIC CO., LTD

DATE	REVISED	APPROVED
------	---------	----------