

P.C.B LAYOUT
BOTTOM VIEW

SCHEMATIC (NON-SHORTING)

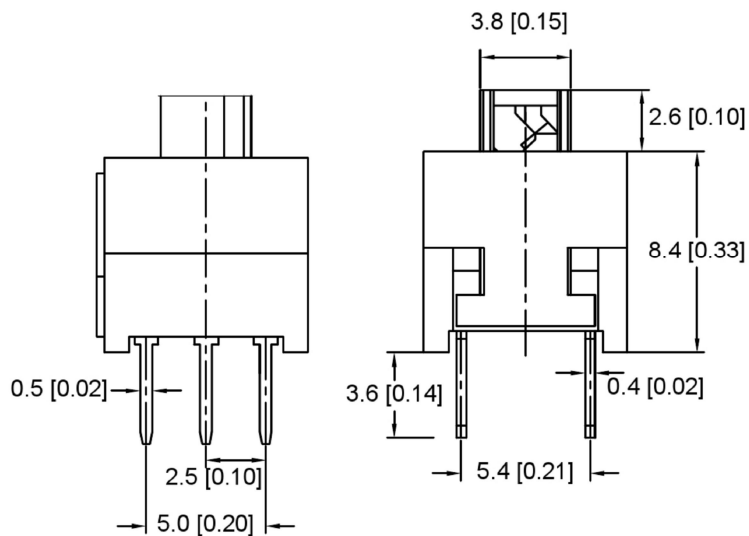
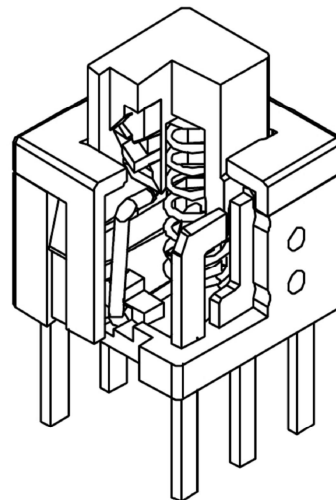

FEATURES

- Light operating force.
- Long term low contact resistance.
- Momentary or latching operation.
- Short stroke 2.0mm to latch.
- Compact spacing on PCB of 8.5mm.

SPECIFICATIONS

1.ELECTRICAL

● Contact rating	0.1A, 30VDC
● Contact resistance	50mWMax
● Insulation resistance	100MMin. at 250VDC
● Dielectric strength	250VAC Min. for 60 sec.

2.MECHANICAL AND ENVIRONMENTAL

● Temperature rating	Operating: -15°C to +55°C Storage: -25 °C to +65 °C
● Operation force	160±80gf
● Stroke	Lock Stroke: 2.0±0.2mm Full Stroke: 2.5±0.2mm
● Operating life	full load: 1x10 ⁴ cycles no load: 1x10 ⁵ cycles
● Contact form	DPDT

PAPT NO	XB8585-X-110
OPERATION	W:NO LOCK Z:LOCK

⑦	Contact	—	2	Phosphor bronze	Plating silvering	—
⑥	Terminal	—	6	Brass	Plating silvering	—
⑤	Spring	—	1	Sus	Natural	—
④	Base	—	1	Pbt		—
③	Crochet Needle	—	1	Sus	Natural	—
②	Cover	—	1	Pom		—
①	Keystake	—	1	Pom		—
ITEM	PAPT NAMF	TER,NO	QTY	MATERIAL	FINISHING	REMARK

DSND		SCALE: N/A	MODEL TYPE: KEY SWITCH
DWN		VIEW:	PART NO.: XB8585-X-110
CHKD		UNIT: mm/in	DWG NO.:
APPD		SIZE: A4	



DONG GUAN XI BANG ELECTRONIC CO., LTD

ANGLAR	±5°		
L ≤ 4	±0.2		
4 < L ≤ 16	±0.3		
16 < L ≤ 63	±0.4		
L > 63	±0.5		
DATE	REVISED	APPROVED	UNSPECIFIED TOLERANCES