

**SCHEMATIC**

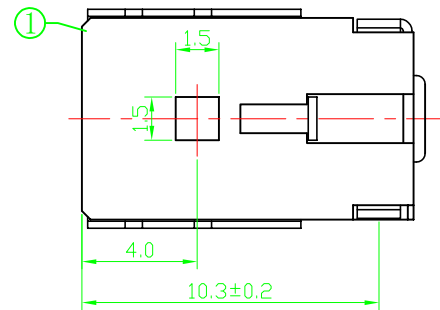

**SPECIFICATION**

- 1. Rating : DC 30V 2.0A;
- 2. Contact resistance:  $\leq 0.03 \Omega$ ;
- 3. Insulation resistance:  $\geq 100M \Omega$  (DC250V);
- 4. Withstand voltage: 500VAC ;
- 5. Insertion and extraction force: 3-20N;
- 6. life test: 5,000 cycles.

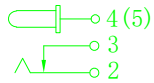
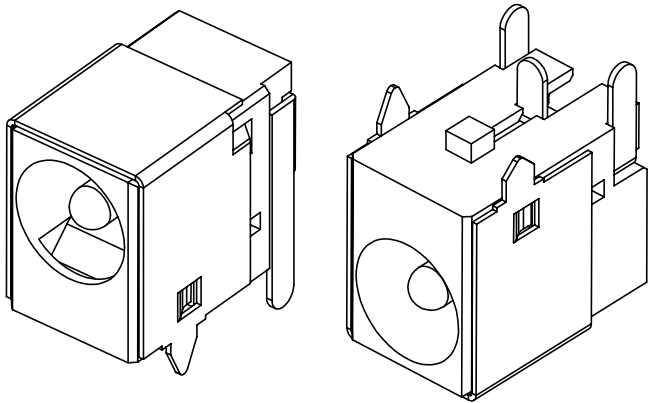

6	COAT	1	BRASS	Ni-Plating
5	PIN	1	BRASS	Ni-Plating
4	CONTACT FOOT	1	BRASS	Ag-Plating
3	CURVE PIECE	1	BRASS	Ag-Plating
2	SPRING	1	SUS301	Ag-Plating
1	HOUSING	1	PBT	
NO.	DESCRIPTION	QTY	MATERIAL	PLATING

UNLESS OTHERWISE SPECIFIED TOLERANCES

**XB** 东莞市溪榜电子有限公司  
DONG GUAN XI BANG ELECTRONICS CO., LTD.

DECIMALS:		ANGLES:		DESIGN:	Tony	PART NAME: Φ5.5板上型 DC POWER JACK	
DIM	TOL	DIM	TOL	CHECK:	2021.7.26		
X.	±0.50	X.	±2°	APPROVED	Andy	PART NO. XB-DC550250-0874-20000H	
X.X	±0.30	X.X	±1°			SHEET: 1/1	REV.: A1
X.XX	±0.20	X.XX	±0.1°				
X.XXX	±0.10	X.XXX	±0.05°			2021.7.26	

REV.	ECN NO.	DESCRIPTION	DESIGN	DATE
------	---------	-------------	--------	------



UNIT: mm

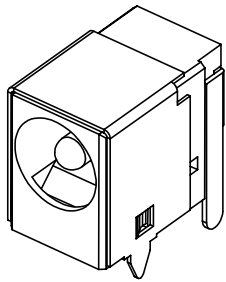

单重:1.64g

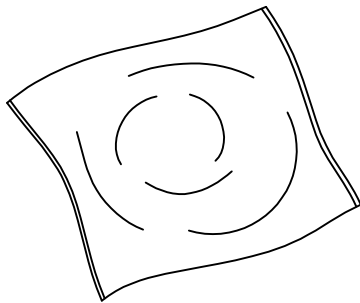
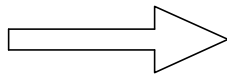

PE袋:500pcs/袋

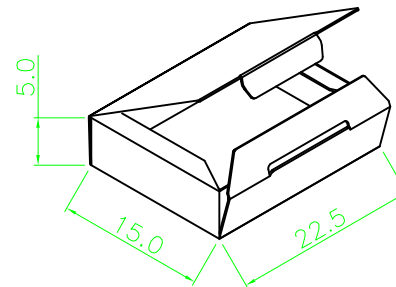
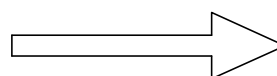

小盒包装: 1袋/盒

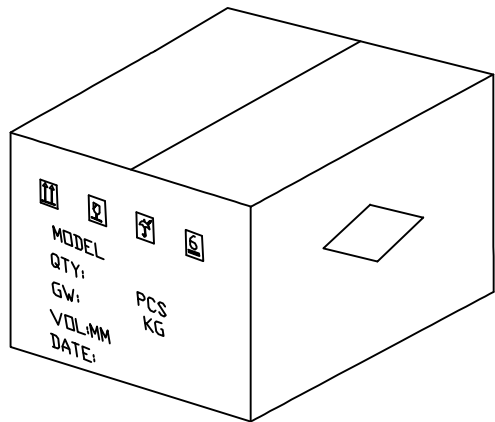

纸箱尺寸: 24\*32\*26 cm  
数量: 5000 PCS  
净重: 8.2 KG  
毛重: 10.0 KG

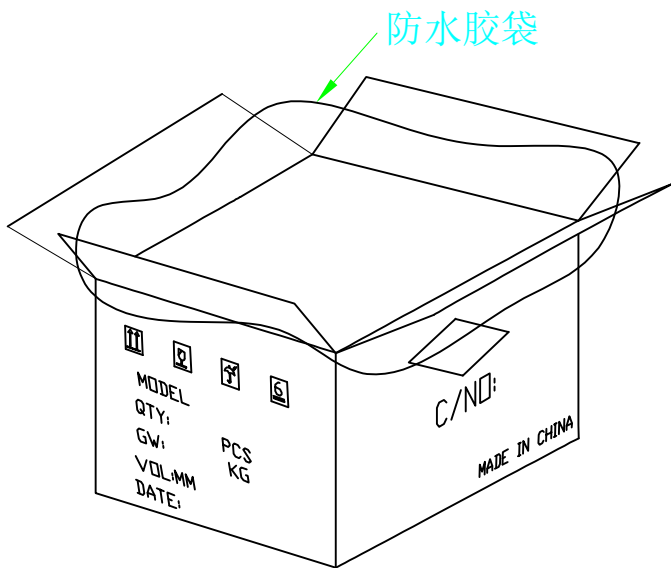
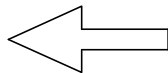

防水胶袋

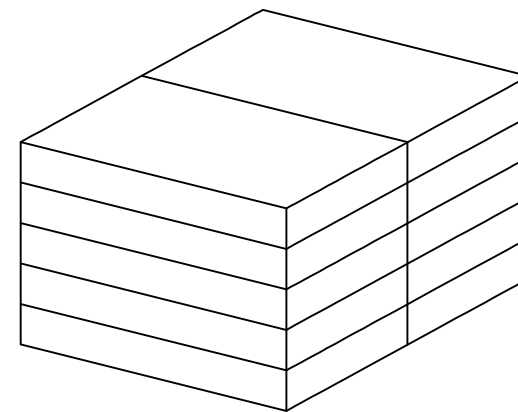

纸箱放入10个小盒, 2\*5

UNLESS OTHERWISE SPECIFIED TOLERANCES



东莞市溪榜电子有限公司  
DONG GUAN XI BANG ELECTRONICS CO., LTD.

DECIMALS:		ANGLES:	
DIM	TOL	DIM	TOL
X.	±0.50	X.	±2°
X.X	±0.30	X.X	±1°
X.XX	±0.20	X.XX	—
X.XXX	±0.10	X.XXX	—

DESIGN:	Tony
	2021.7.26
CHECK:	
APPROVED	Andy
	2021.7.26

PART NAME:	Φ5.5板上型 DC POWER JACK-包装图
PART NO.	XB-DC550250-0874-20000H
SHEET: 1/1	REV.: A1
DRAWING NO	

REV.	ECN NO.	DESCRIPTION	DESIGN	DATE
8				
7				
6				
5				
4				
3				
2				
1				



UNIT: mm