

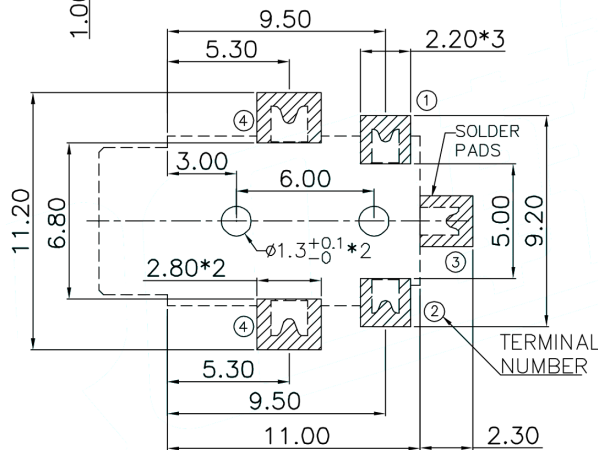

CAD FILE:

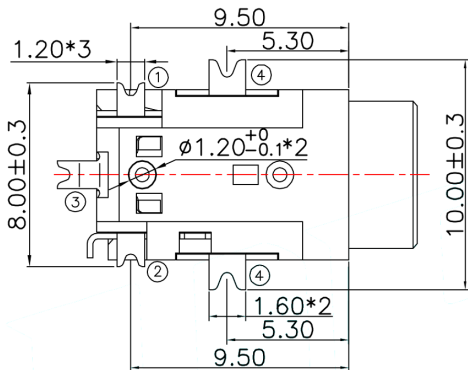

PAD LAYOUT (TOP)

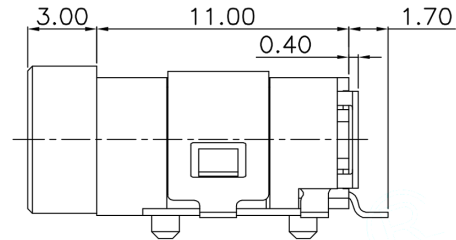
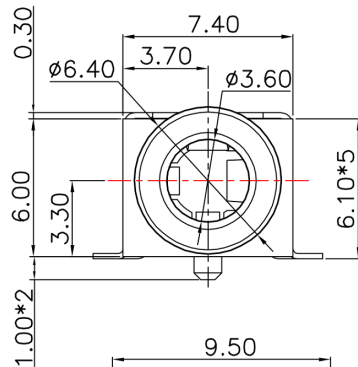
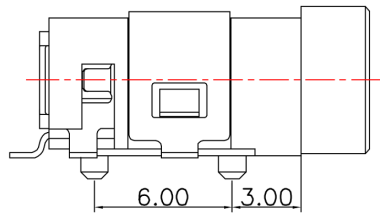
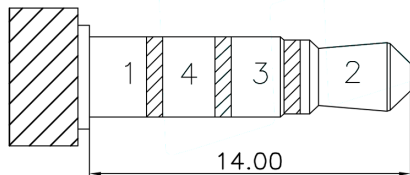
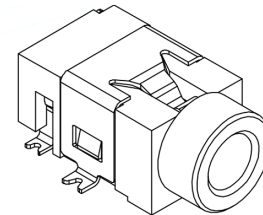
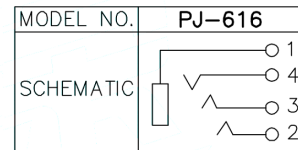

ø3.5 MATE PLUG

NOTES:

- CONTACT CURRENT RATING:12V 1A.
- CONTACT RESISTANCE: 50mΩ MAX.;
- INSULATION RESISTANCE: 100M MIN.500V DC;
- DIELECTRIC WITHSTANDING: 500V AC MIN.;
- DURABILITY: 5,000 CYCLES MIN.;
- CONNECTOR MATING FORCES:29.4N (3.00Kgf) MAX.;
- CONNECTOR UNMATING FORCES:2.94N(0.30Kgf) MIN.;

| | | | | | | | | | | | | | | | | | | | | |
|-----|---------|-----------------|------|-----------------|--|--|-------|--|------------|--|--------------------------|--|-----------|--|-----------|--|--|--|------------|--|
| 8 | | | | | | | | | | | | | | | | | | | | |
| 7 | | | | | | | | | | | | | | | | | | | | |
| 6 | | | | | | | | | | | | | | | | | | | | |
| 5 | | | | | | | | | | | | | | | | | | | | |
| 4 | CONTACT | SUS | 1 | Ag CLAD | | | | | | | | | | | | | | | | |
| 3 | CASE | PPA/BRASS SRTIP | 1 | BLACK/Ag PLATED | | | | | | | | | | | | | | | | |
| 2 | COVER | STEEL STRIP | 1 | Ni PLATED | | | | | | | | | | | | | | | | |
| 1 | KNOB | PPA | 1 | BLACK | | | | | | | | | | | | | | | | |
| NO. | PARTS | MATERIALS | Q'TY | FINISH | | | | | | | | | | | | | | | | |
| | | | | | TOLERANCE UNLESS SPECIFIED | | | | | | | | | | | | | | | |
| | | | | | WITHIN 1.5mm : ±0.1mm | | A | | 2023-6-21 | | 初版 | | | | | | | | ZENQ. CHEN | |
| | | | | | OVER 1.5mm : ±0.2mm | | ISSUE | | DATE | | DESCRIPTIONS OF REVISION | | | | | | | | APPD. | |
| | | | | | TITLE : Audio iack | | | | UNIT : mm | | DRWG NO.: XB-PJ-616 | | | | | | | | | |
| | | | | | MODEL: | | | | SCALE: 5:1 | | DWN. | | JUN. YANG | | 2023-6-21 | | | | | |
| | | | | | 东莞市溪榜电子有限公司 | | | | CHK'D | | DONG. PANG | | 2023-6-21 | | | | | | | |
| | | | | | DONG GUAN XI BANG ELECTRONI CS CO., LTD. | | | | APPD. | | ZENQ. CHEN | | 2023-6-21 | | | | | | | |