

CAD FILE:

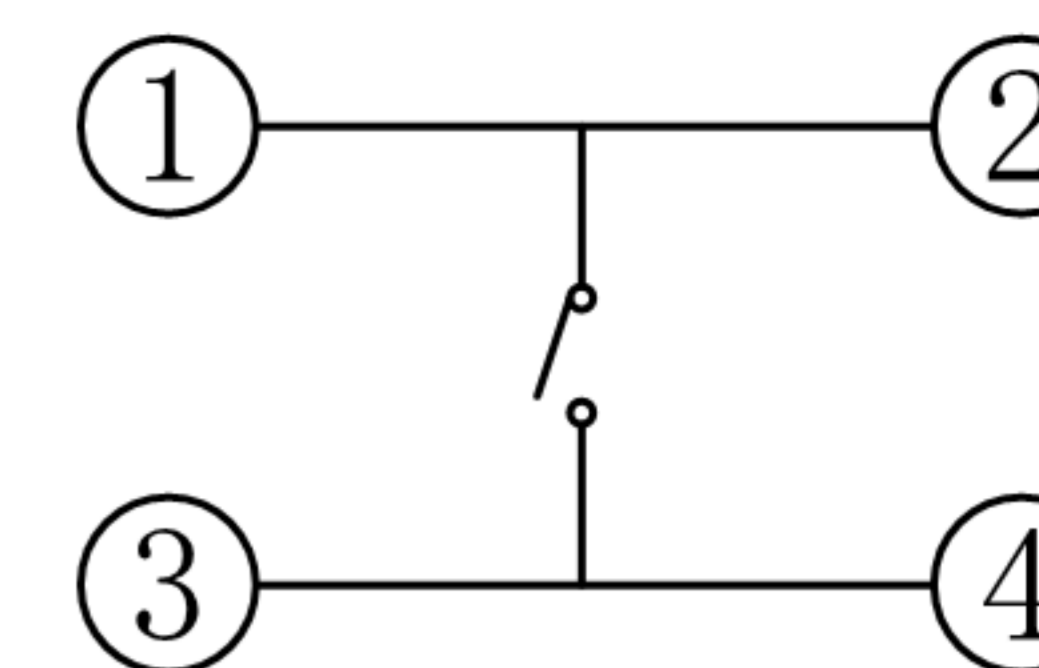

SCHEMATIC

H	
4.6	4.8
5.3	5.8
6.3	6.8
.....
13.3	13.8
14.3	14.8

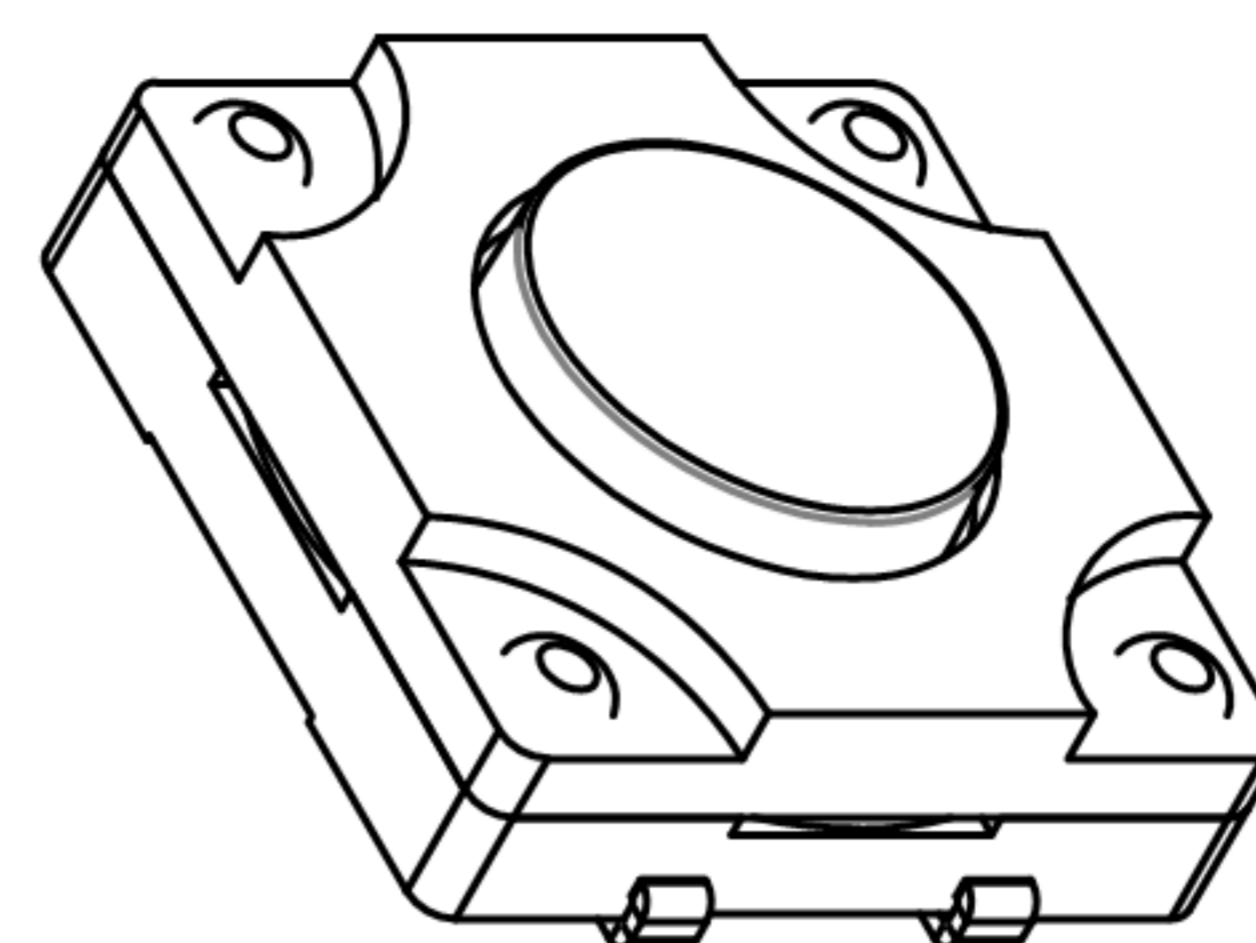
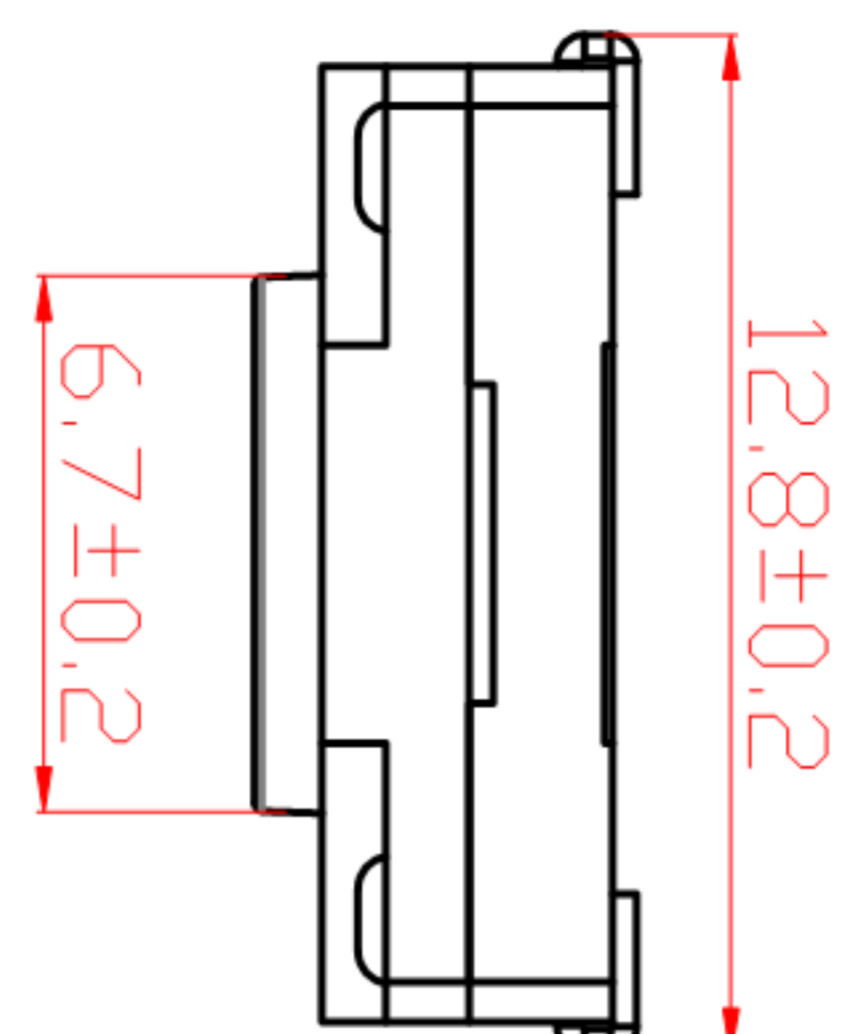
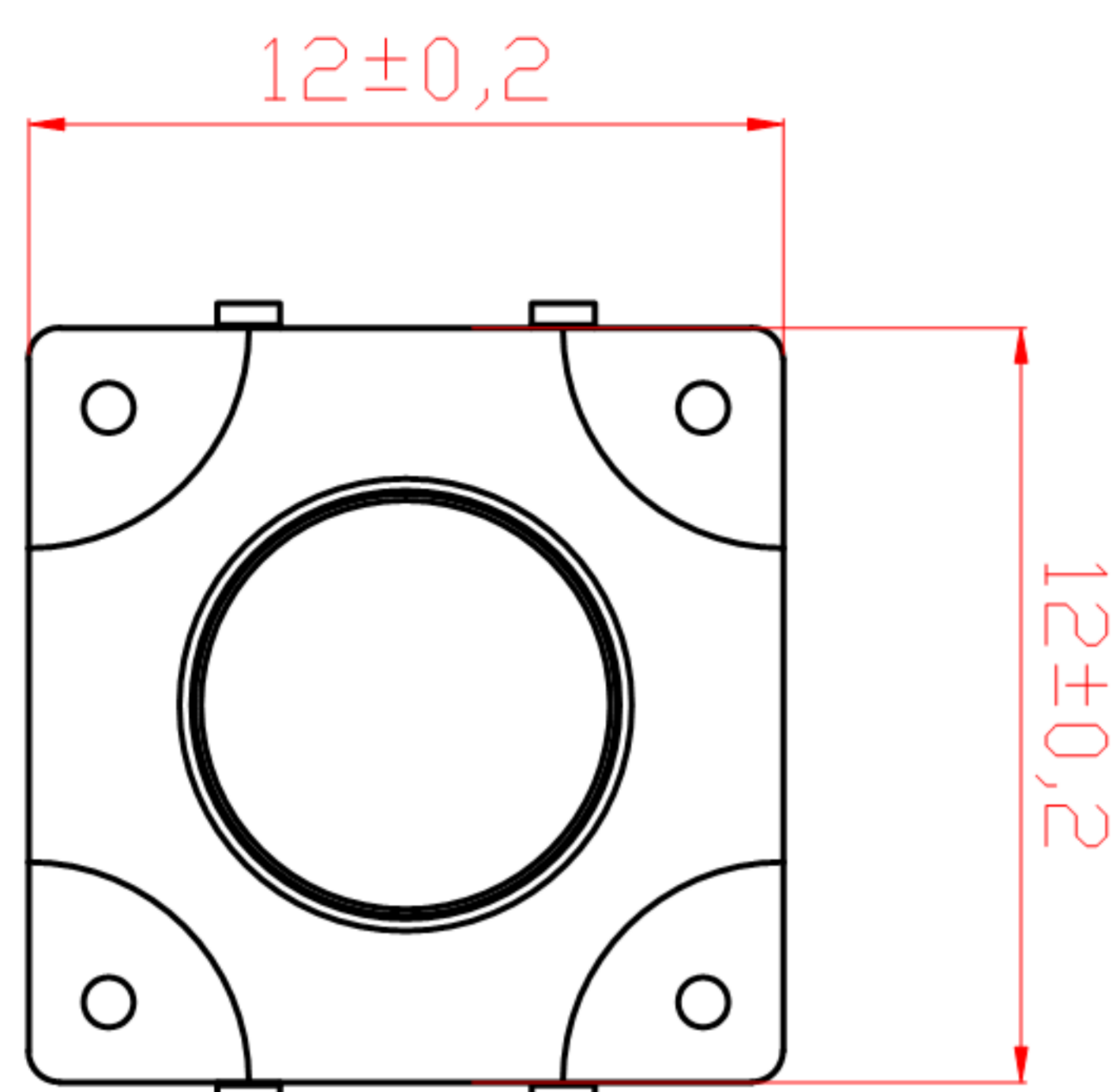
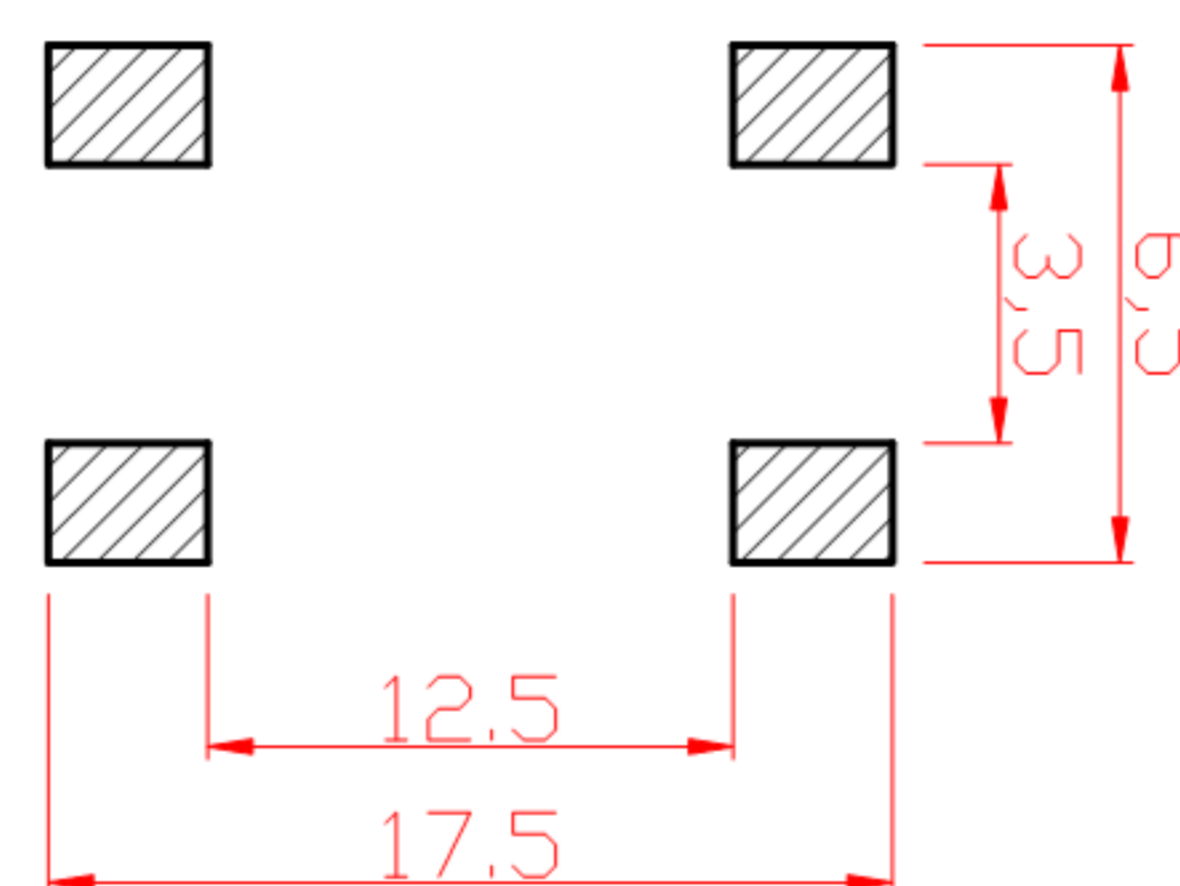
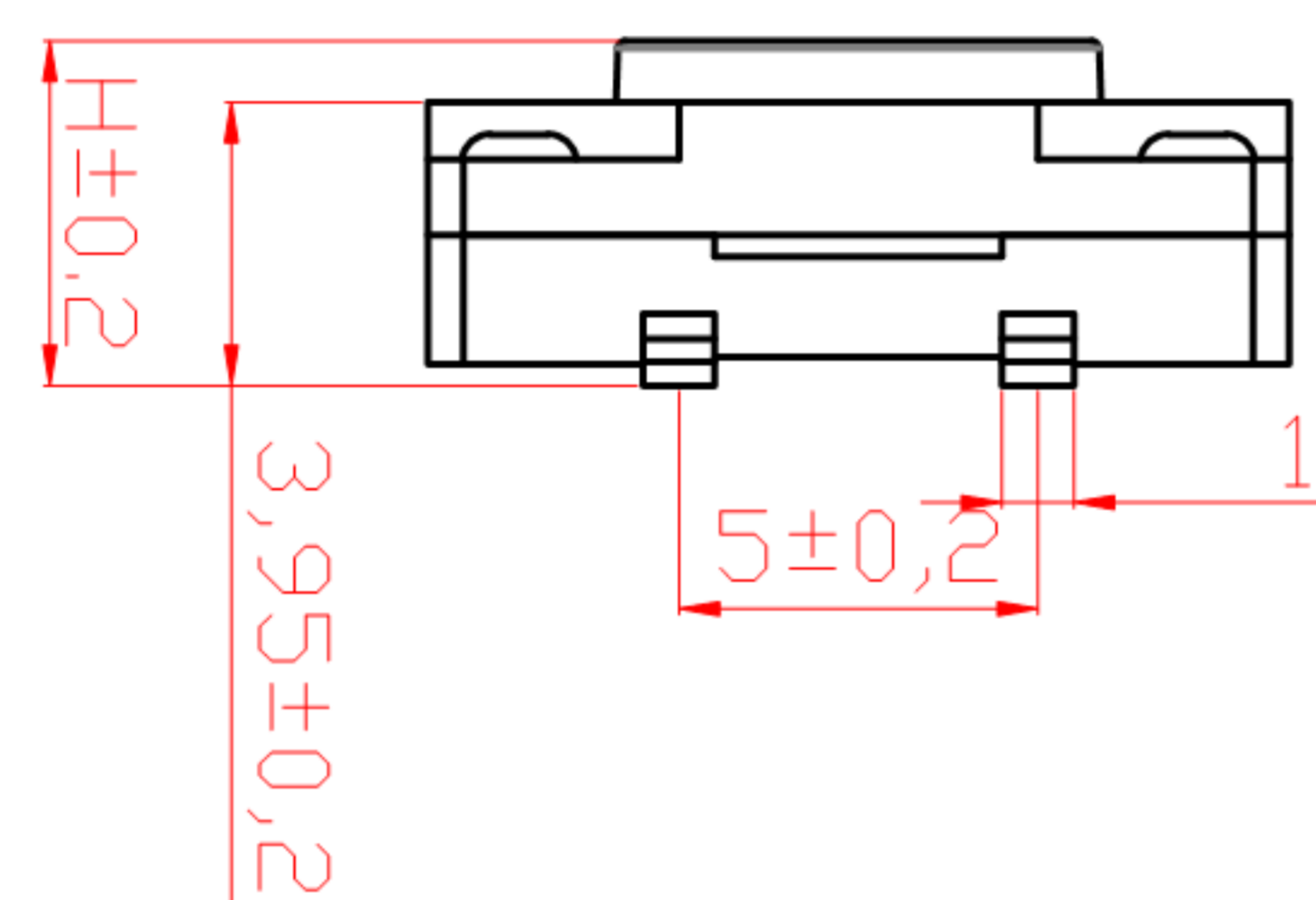
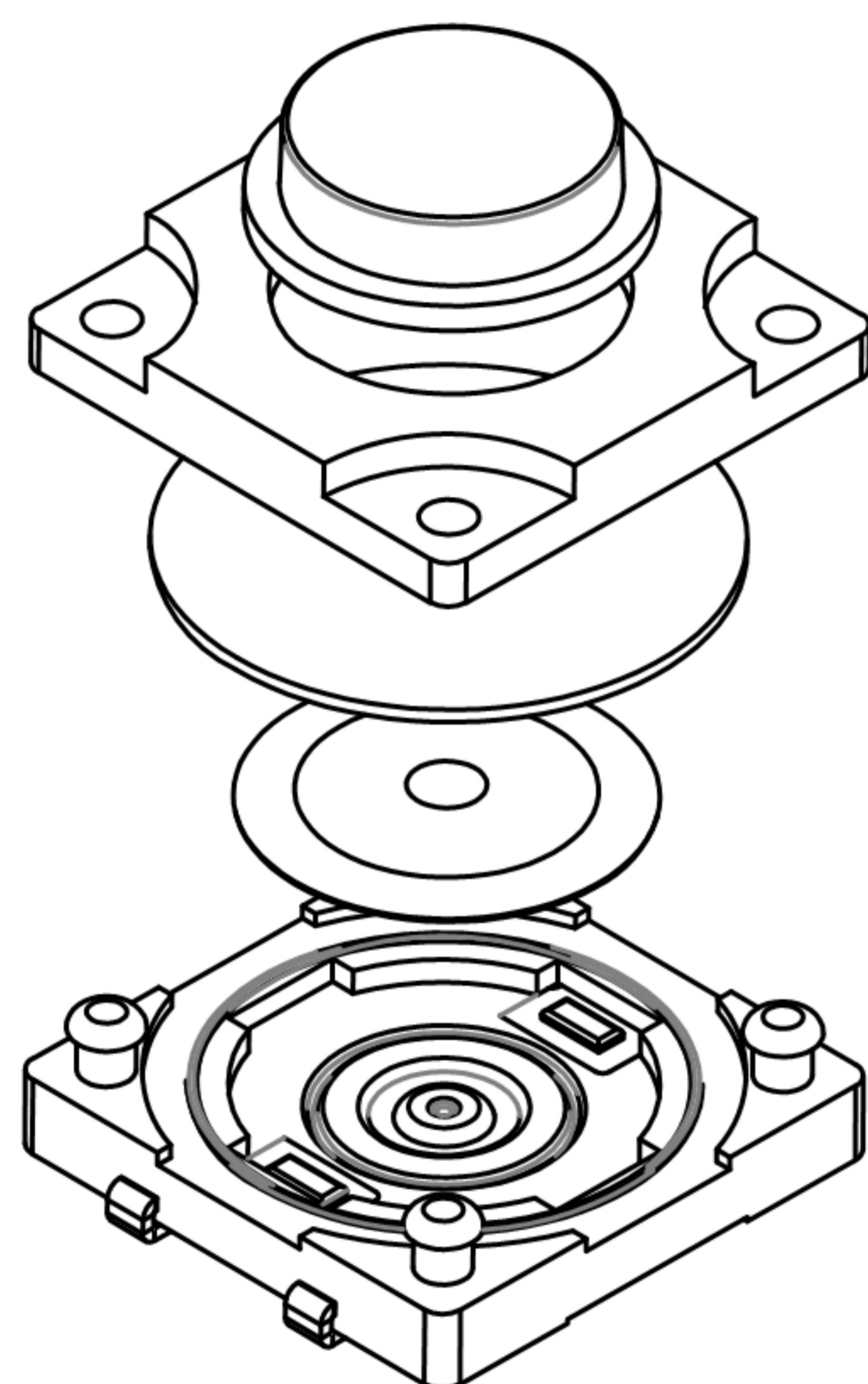

PCB. 焊接图

主要技术规格:

1. 额定值: 50mA DC12V
2. 接触电阻: $\leq 50m\Omega$
3. 操作力: $250 \pm 40gf$
4. 行程: $0.45 \pm 0.1mm$
5. 绝缘电阻: $\geq 100M\Omega$
6. 抗电强度: 250V 50HZ 1Min.
7. 寿命: 100,000 Cycles
8. 防水等级: IP67
9. 防银迁移: 60V, 85°C, 90%RH/60H

NO.	PARTS	MATERIALS	Q'TY	FINISH	TOLERANCE UNLESS SPECIFIED	DATE	DESCRIPTIONS OF REVISION	APPD.
8								
7								
6					WITHIN 1.5mm : $\pm 0.1mm$	A	初版	ZENQ. CHEN
5					OVER 1.5mm : $\pm 0.2mm$	ISSUE	DATE	APPD.
4	CONTACT	SUS	1	Ag CLAD	TITLE : TACT SWITCH		UNIT : mm	DRWG NO.: XB-TS-FS12-UM
3	CASE	PPA/BRASS SRTIP	1	BLACK/Ag PLATED	MODEL:		SCALE: 5:1	DWN. JUN. YANG 2012-9-25
2	COVER	STEEL STRIP	1	Ni PLATED			CHK'D	DONG. PANG 2012-9-25
1	KNOB	PPA	1	BLACK			APPD.	ZENQ. CHEN 2012-9-25
					东莞市溪榜电子有限公司 DONG GUAN XI BANG ELECTRONICS CO., LTD.			