

Section B-B

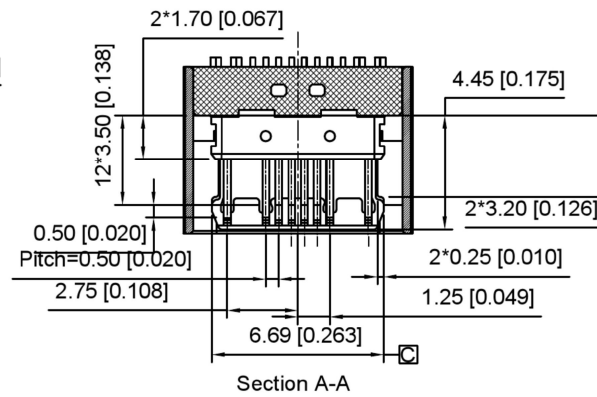
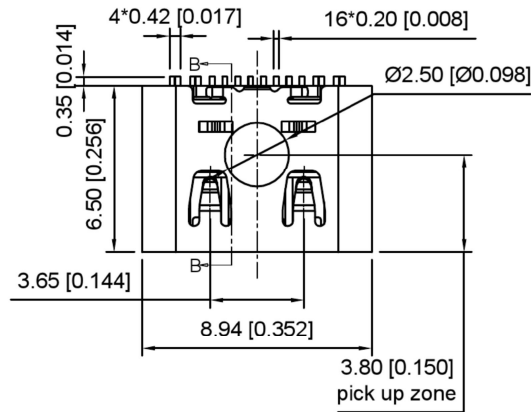

Section A-A

PIN DEFINE TABLE			
PIN	SIGNAL	PIN	SIGNAL
A12	GND	B1	GND
A11		B2	
A10		B3	
A9	VBUS	B4	VBUS
A8	SBU1	B5	CC2
A7	Dn1	B6	Dp2
A6	Dp1	B7	Dn2
A5	CC1	B8	SBU2
A4	VBUS	B9	VBUS
A3		B10	
A2		B11	
A1	GND	B12	GND

SPECIFICATION:

1. Material

- Housing Material: High temperature thermoplastic
- Contact Terminal: High Grade Copper Alloy
- Metallic Shell: Stainless Steel
- Inner Ground Cover Shell: Stainless Steel
- Mid Plate: Stainless Steel

2. Mechanical:

- 2.1. Mating force: 5-20Nf;
- 2.2. Unmating force: Initial: 8-20Nf; Final: 6-20Nf;
- 2.3. Durability: 10000 Cycles;

3. Electrical:

- 3.1. Current Rating: VBus Pins: 5A, Vconn Pin: 1.25A, Other Pins: 0.25A;

- 3.2. Voltage Rating: 20V Max.;
- 3.3. Dielectric Withstanding voltage: 100Vac, 60S, 10mA;
- 3.4. Contact resistance: 40m Ohms Max.;
- 3.5. Insulation Resistance: 100M Ohms Min.;

4. Environmental:

- 4.1. Operating temperature: -40°C~+85°C;
- 4.2. Salt Spray Test: 48H Min. (No oxidation or rust);
- 4.3. Wetting Temperature: 265±5°C, 5±0.5s

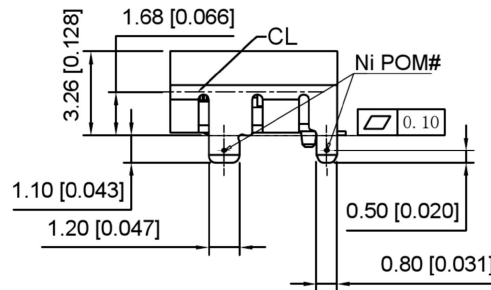
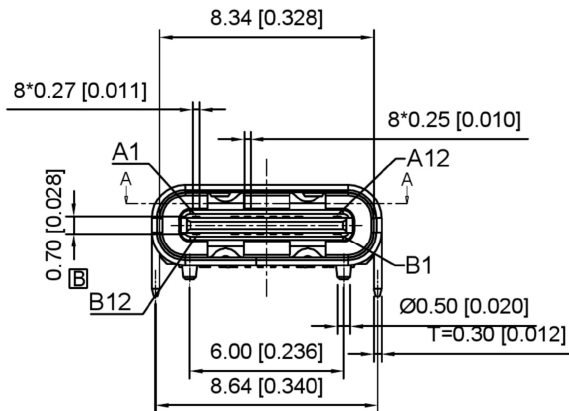

U262-16XN-4BS165

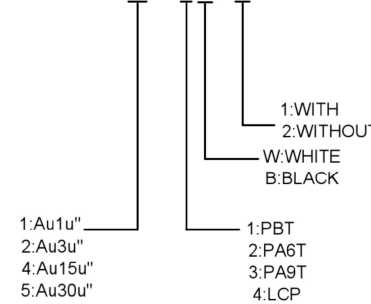

REVISIONS	DATE	REVISED	APPROVED	UNSPECIFIED TOLERANCES
				ANGULAR ±5°
				L ≤ 4 ±0.2
				4 < L ≤ 16 ±0.3
				16 < L ≤ 63 ±0.4
				L > 63 ±0.5



DSND	SCALE: N/A	MODEL TYPE: Type-C 3.1
DWN	VIEW:	PART NO.:
CHKD	UNIT: mm/in	DWG NO.: U262-16XN-4BS165
APPD	SIZE: A4	WEIGHT SHEET REVISION
DONG GUAN XI BANG ELECTRONIC CO., LTD		1/1 A0