

- 规格 Specifications:
- 额定电压 Voltage rating: 250V AC/DC
 - 额定电流 Current rating: 3A AC/DC
 - 耐电压 Withstanding voltage: 1500V AC/minute
 - 温度区间 Temperature range: -40°C~+105°C
 - 绝缘电阻 Insulation resistance: ≥500MΩ
 - 接触电阻 Contact resistance: ≤10mΩ
 - 环境测试后 After environmental testing: ≤20mΩ

X2521 T F- P SN-G
 ① ② ③ ④ ⑤ ⑥

- ① Series No.
- ② Category: T-Terminal
- ③ Welding Board Angle: F-Female
- ④ Material: P-Phosphor Bronze
- ⑤ Plating style: SN-Bright tin plating
- ⑥ G: mating -G

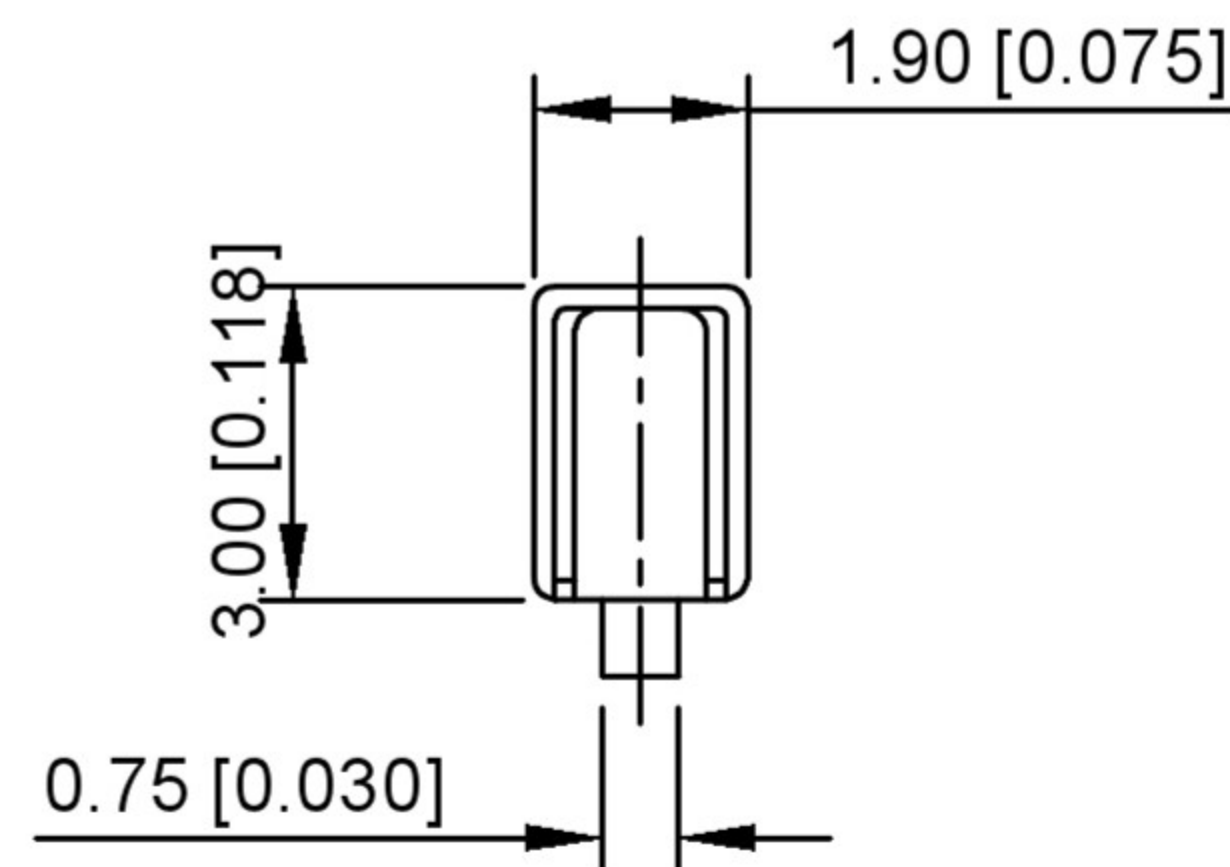
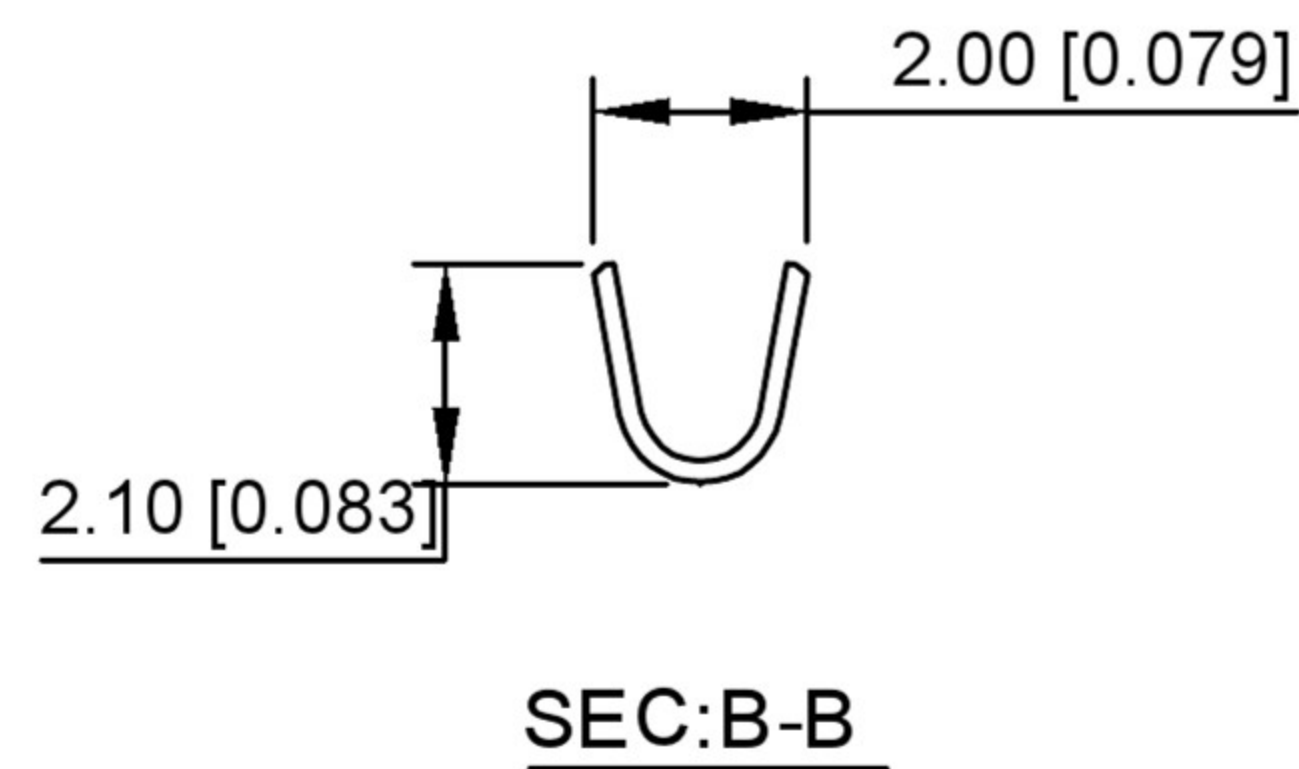
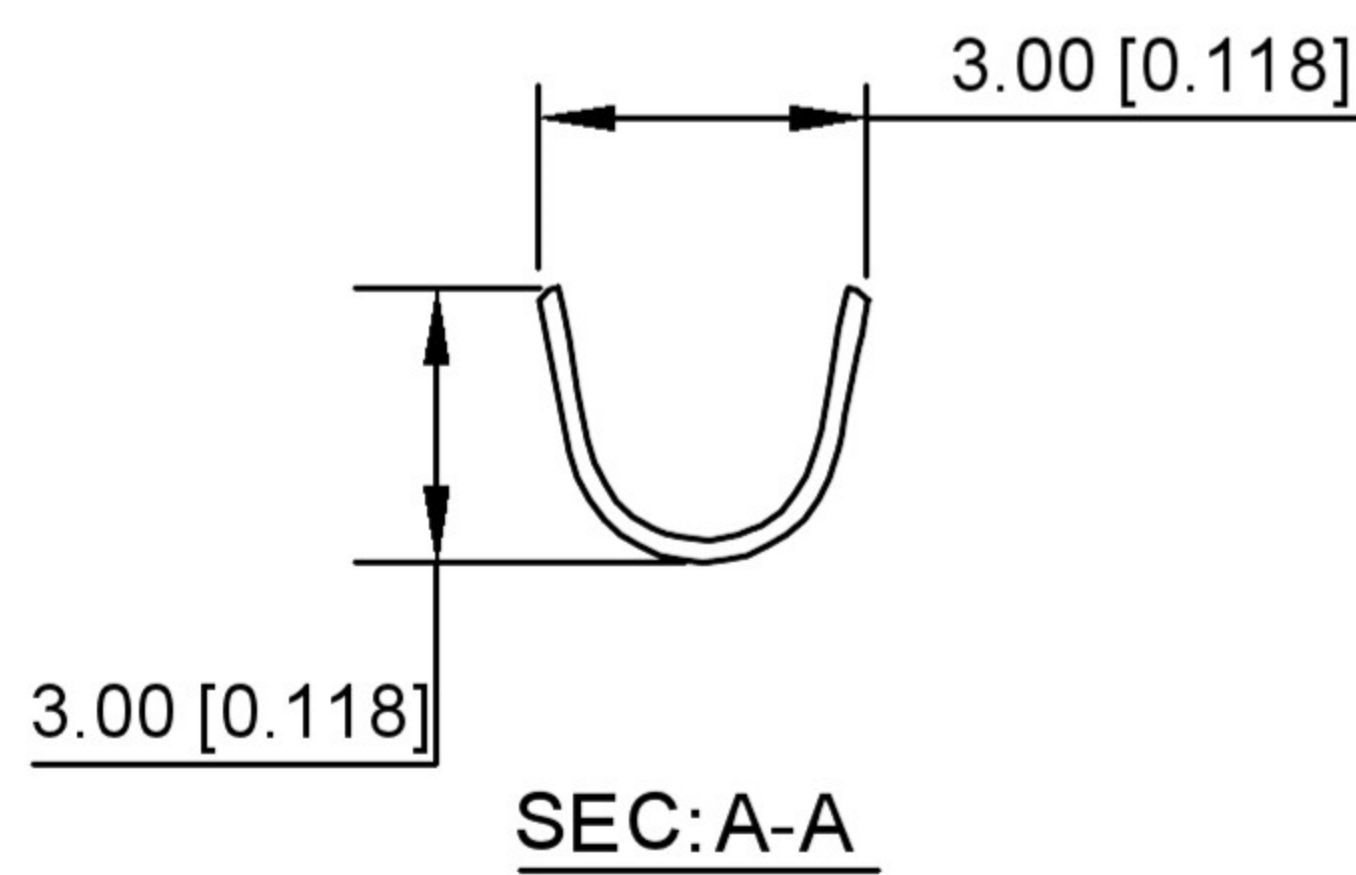

X2521TF-PSN-G	Phosphor Bronze	AWG#22-28	X2521HM
PART NO	Material	Wire Range	Suitable Housing

REVISIONS				ANGULAR	±5°		DSND	SCALE: N/A	MODEL TYPE:
				L ≤ 4	±0.2		DWN	VIEW:	2.5mm Crimp Style Connector
				4 < L ≤ 16	±0.3		CHKD	UNIT: mm/in	PART NO.:
				16 < L ≤ 63	±0.4		APPD	SIZE: A4	XB-X0600WRS-XX-LPV01HF
DATE				REVISED	APPROVED	L > 63	UNSPECIFIED TOLERANCES	DWG NO.:	
www.alpsr.com www.gdxjdz.com www.xbswitch.com				DONG GUAN XI BANG ELECTRONIC CO., LTD			WEIGHT		SHEET
							1/1		REVISION
									A0

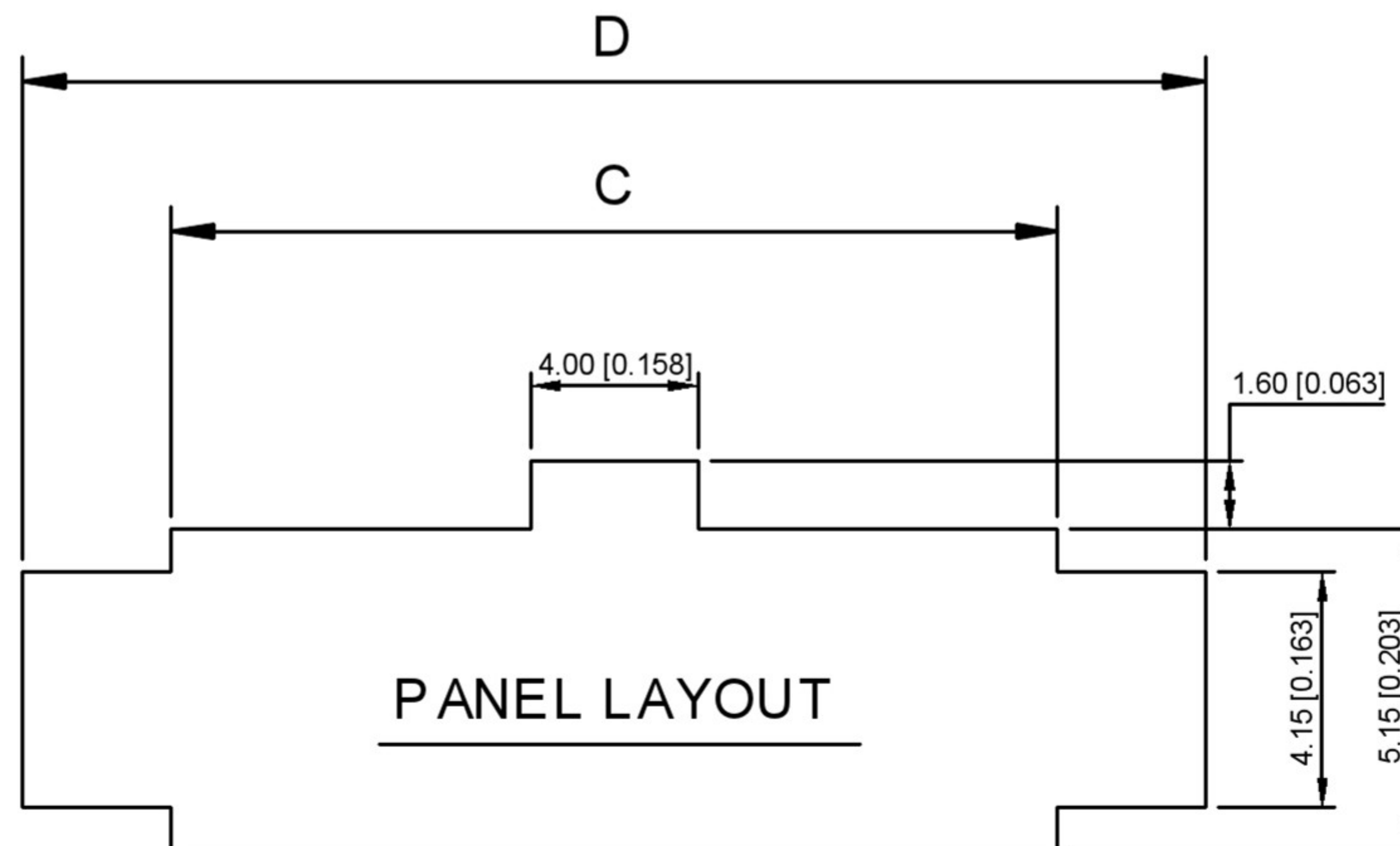
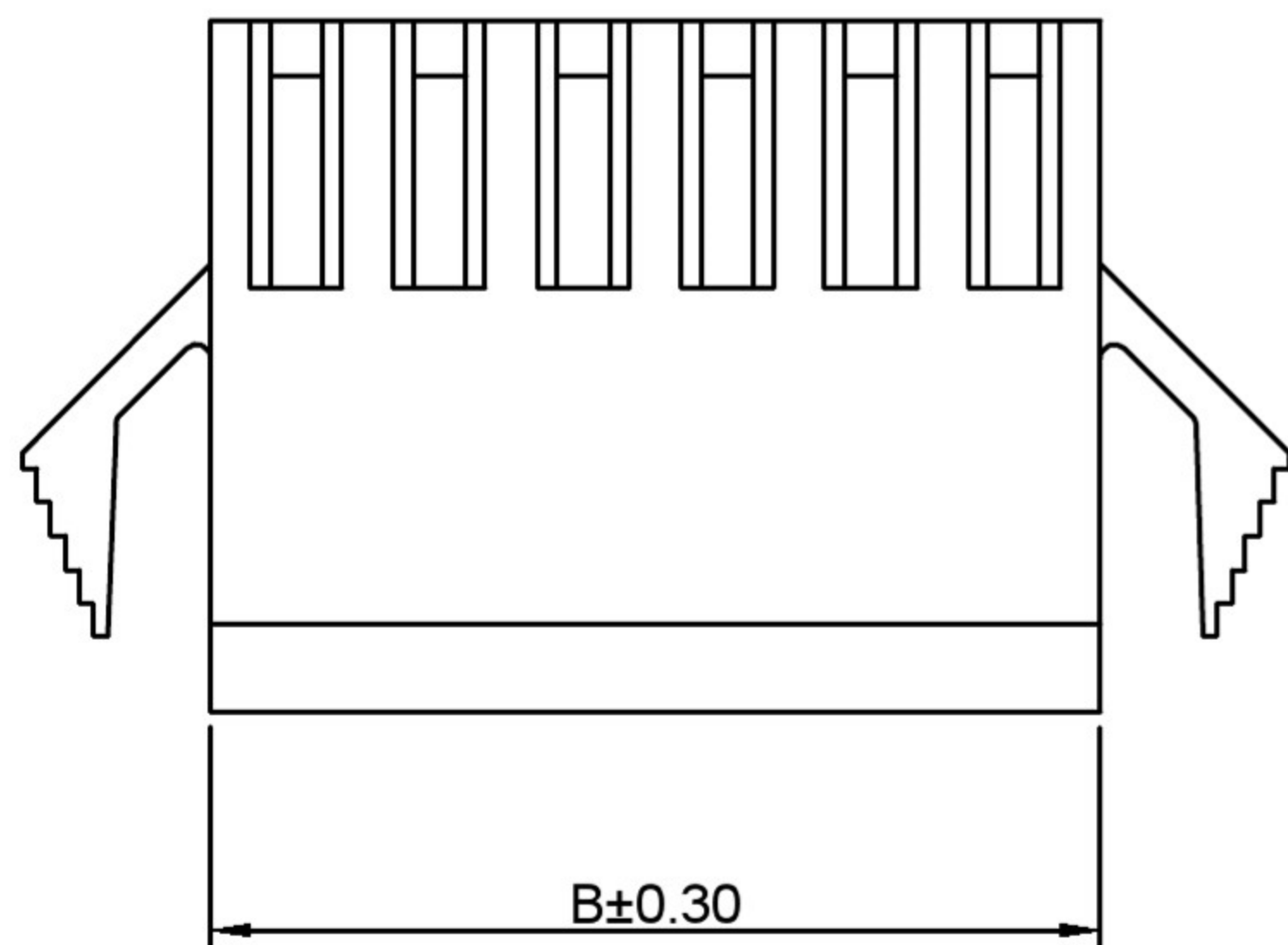
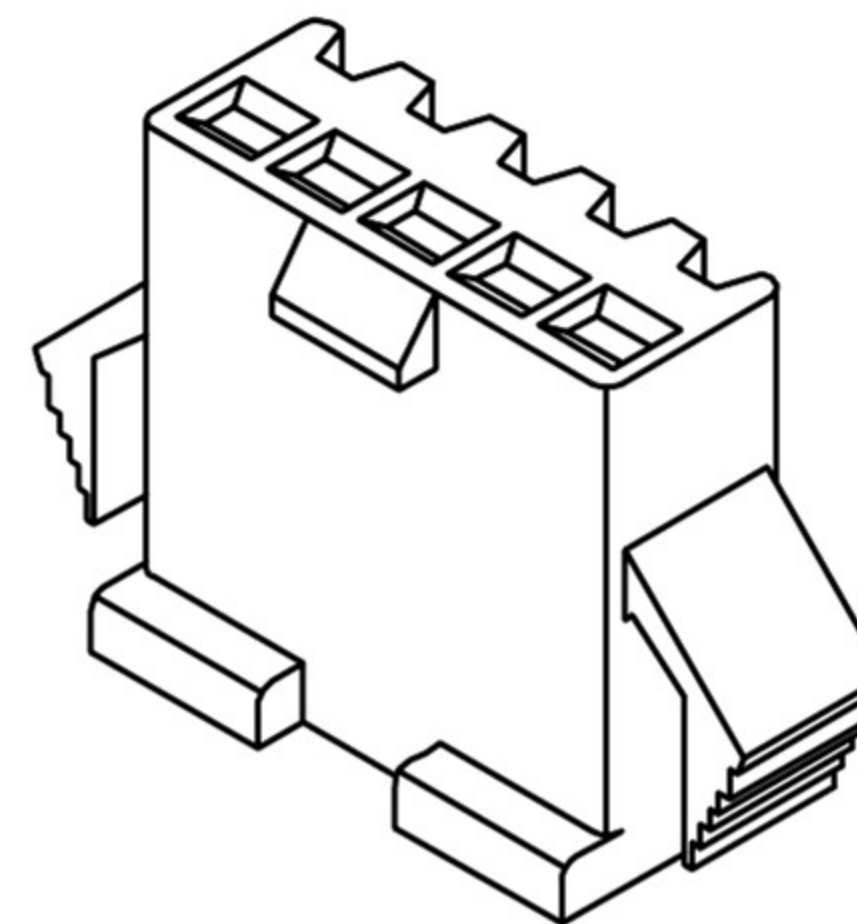
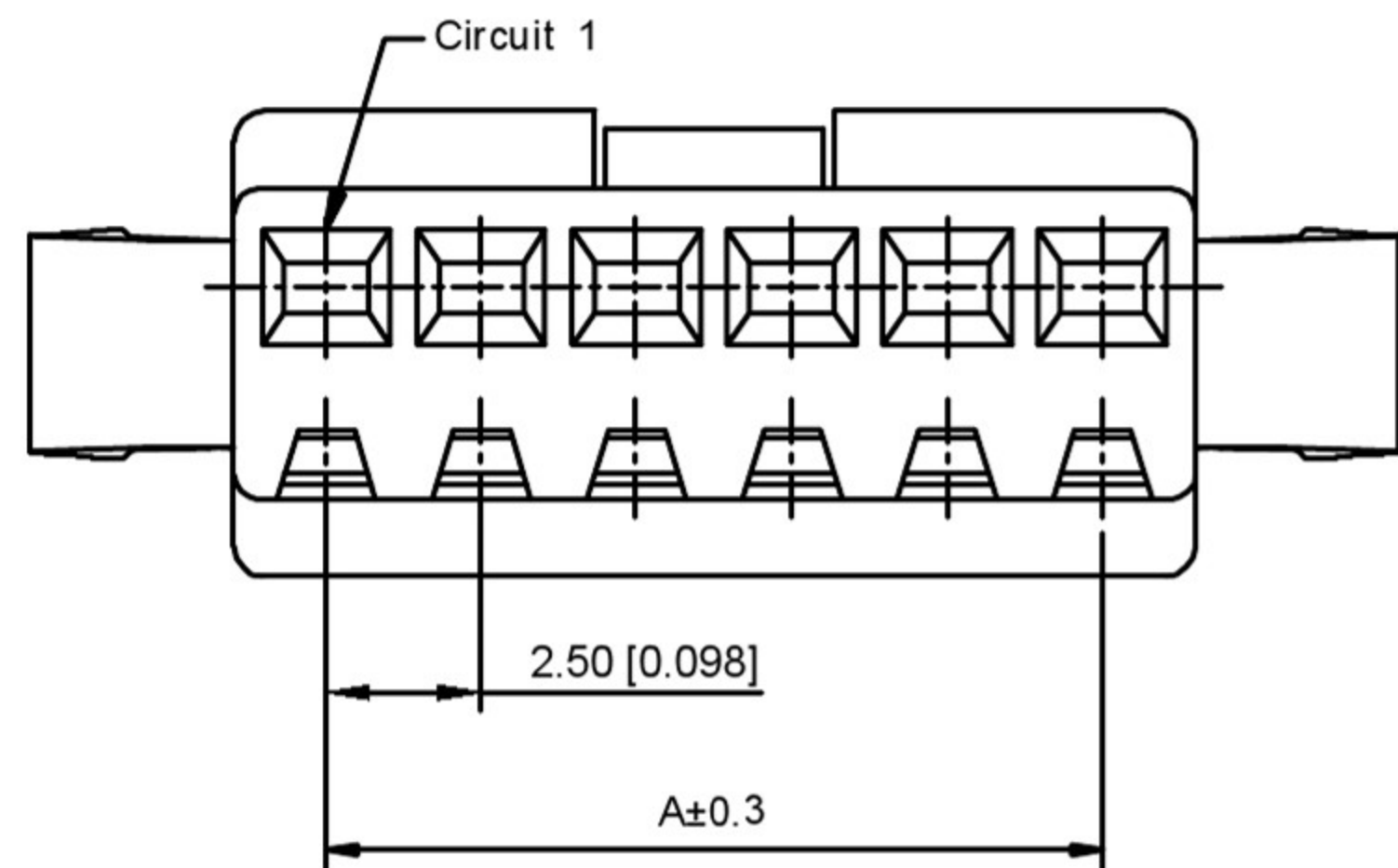
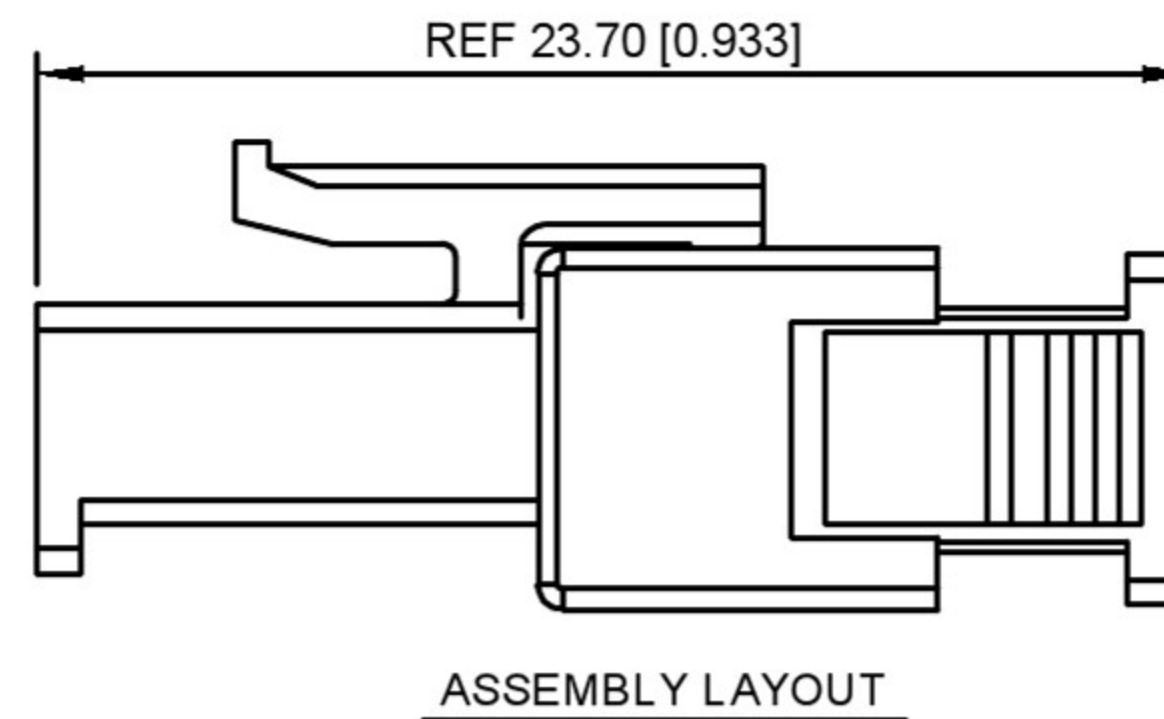
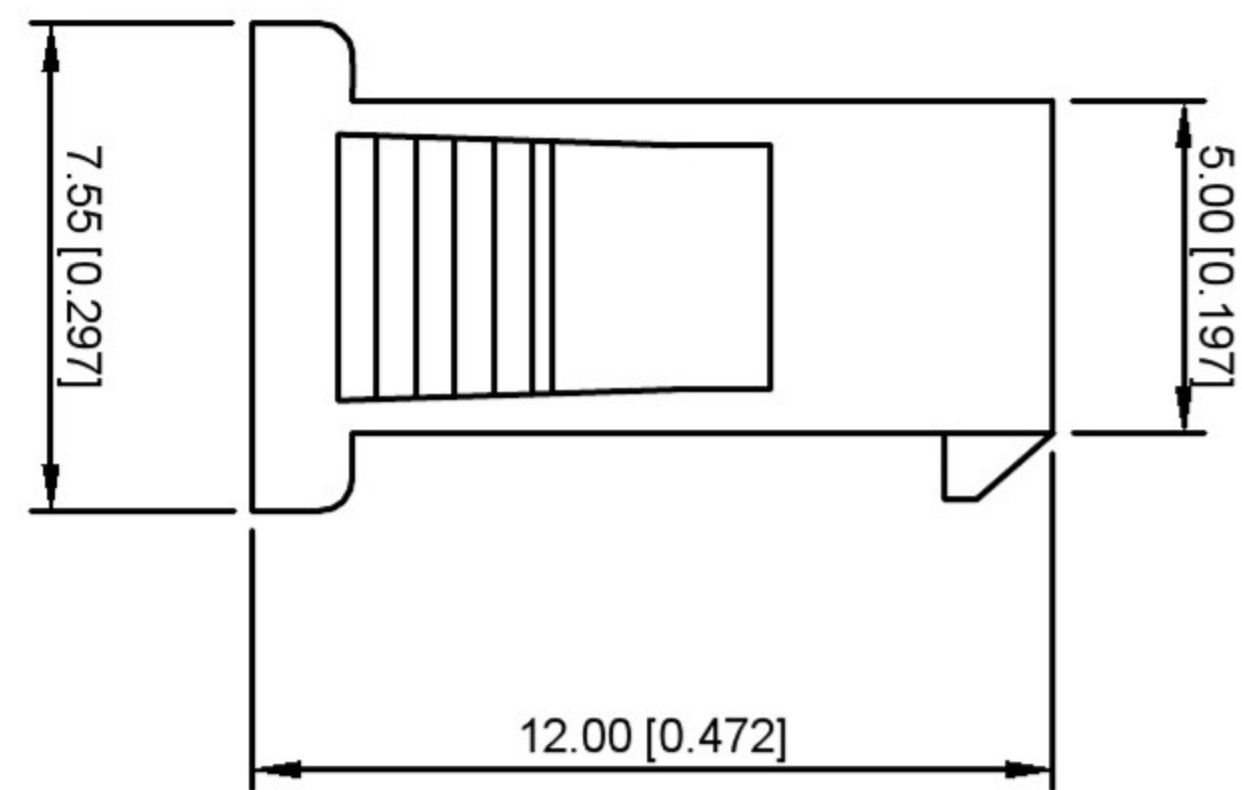

■ 规格 Specifications:

- 额定电压 Votage rating:250V AC/DC
- 额定电流 Current rating:3A AC/DC
- 耐电压 Withstanding voltage:1500V AC/minute
- 温度区间 Temperature range:-40℃~+105℃
- 绝缘电阻 Insulation resistance:≥500MΩ
- 接触电阻 Contact resistance:≤10mΩ
- 环境测试后 After environmental testing:≤20mΩ

X2521 H M- XX G-N0

① ② ③ ④ ⑤ ⑥

- ① Series No.
- ② Category:H-HSG
- ③ Welding Board Angle:M-male HSG
- ④ Row No.-Pin No.:XX-02P~12P
- ⑤ Plug the Pin & Spcial No.:Mating X2521HF-G
- ⑥ Material:N0-PA66 94V-0

Poles	Applicable Panel thickness mm					
	0.5~0.9		1.0~1.5		1.5~2.0	
	C	D	C	D	C	D
02	5.7	9.6	5.7	9.8	5.7	10.0
03	8.2	12.1	8.2	12.3	8.2	12.5
04	10.7	14.6	10.7	14.8	10.7	15.0
05	13.2	17.1	13.2	17.3	13.2	17.5
06	15.7	19.6	15.7	19.8	15.7	20.0
07	18.2	22.1	18.2	22.3	18.2	22.5
08	20.7	24.6	20.7	24.8	20.7	25.0
09	23.2	27.1	23.2	27.3	23.2	27.5
10	25.7	29.6	25.7	29.8	25.7	30.0
11	28.2	32.1	28.2	32.3	28.2	32.5
12	30.7	34.6	30.7	34.8	30.7	35.0

Poles	Dimensions(mm)		Poles	Dimensions(mm)	
	A	B		A	B
02	2.50	5.50	08	17.50	20.50
03	5.00	8.00	09	20.00	23.00
04	7.50	10.50	10	22.50	25.50
05	10.00	13.00	11	25.00	28.00
06	12.50	15.50	12	27.50	30.50
07	15.00	18.00			

X2521HM-XXG-N0	Black	PA66 UL94V-0	Brass	Tin-Plated	X2521HF
PART NO	Color	Material	Material(Pin)	Finsh(Pin)	Suitable Housing

REVISIONS	DATE	REVISED	APPROVED	ANGLAR	±5°
				L ≤ 4	±0.2
				4 < L ≤ 16	±0.3
				16 < L ≤ 63	±0.4
				L > 63	±0.5

UNSPECIFIED TOLERANCES



DSND	SCALE: N/A
DWN	VIEW:
CHKD	UNIT: mm/in
APPD	SIZE: A4

MODEL TYPE: 2.5mm Crimp Style Connector
PART NO.: XB-X0600WRS-XX-LPV01HF
DWG NO.:

DONG GUAN XI BANG ELECTRONIC CO., LTD

WEIGHT	SHEET	REVISION
	1/1	A0

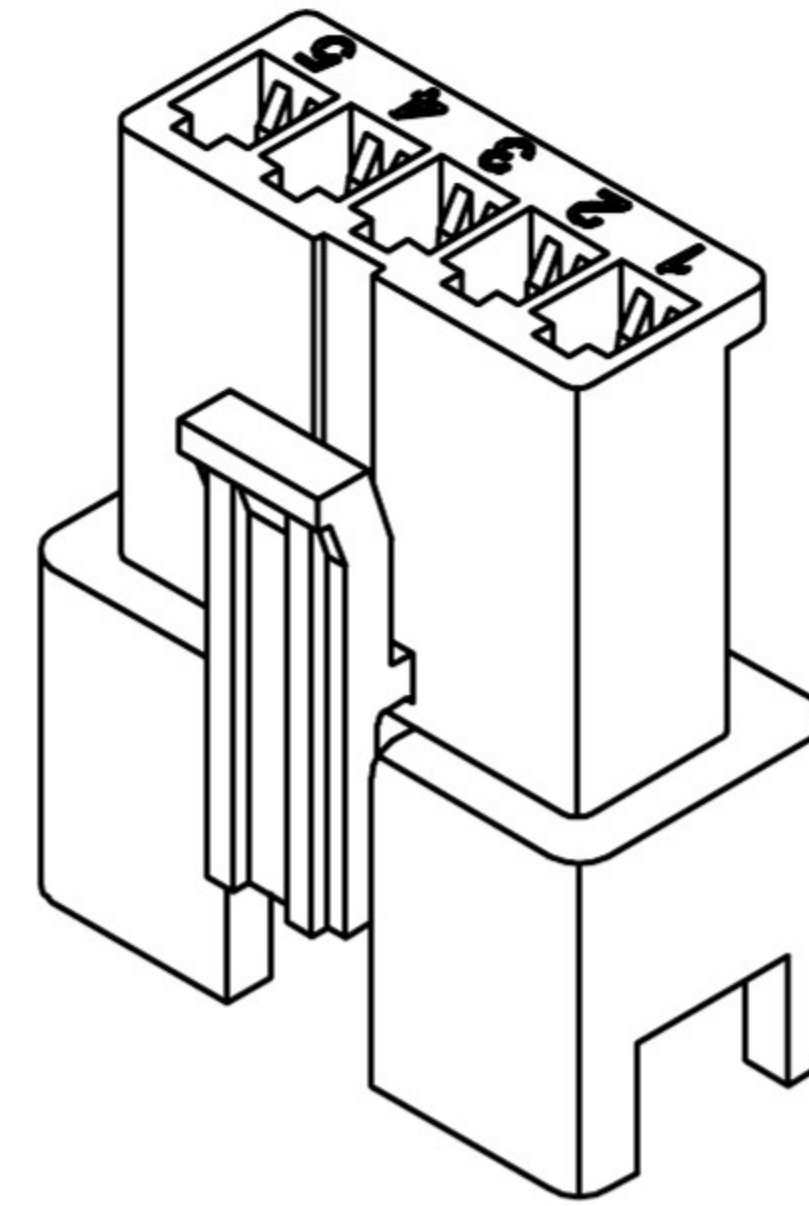
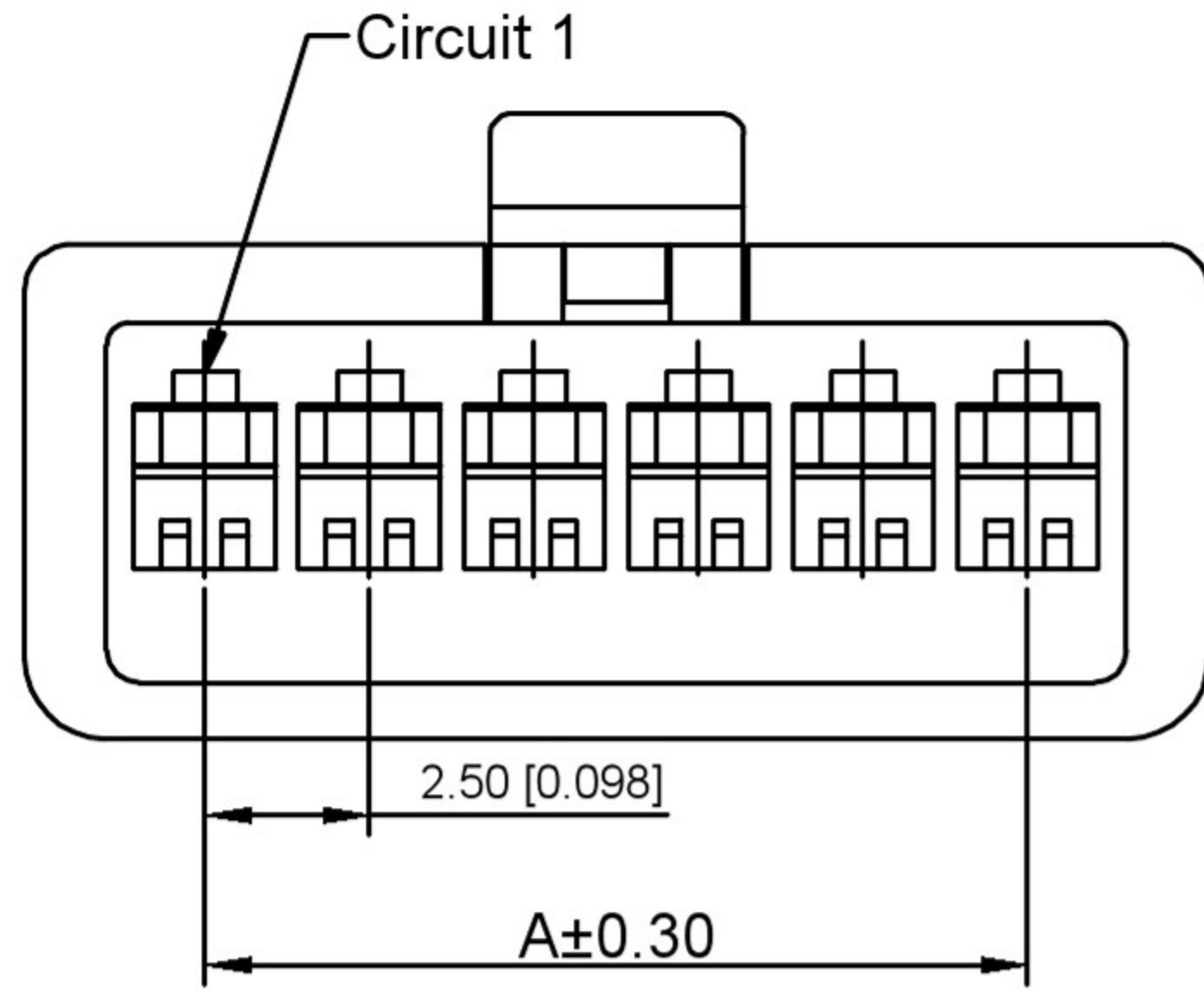

规格 Specifications:

- 额定电压 Votage rating:250V AC/DC
- 额定电流 Current rating:3A AC/DC
- 耐电压 Withstanding voltage:1500V AC/minute
- 温度区间 Temperature range:-40℃~+105℃
- 绝缘电阻 Insulation resistance:≥500MΩ
- 接触电阻 Contact resistance:≤10mΩ
- 环境测试后 After environmental testing:≤20mΩ

X2521 H F- XX G-N0
 ① ② ③ ④ ⑤ ⑥

- ① Series No.
- ② Category:H-HSG
- ③ Welding Board Angle:F-Female HSG
- ④ Row No.-pin No.:XX-02P~12P
- ⑤ Plug the pin & Spcial No.:G-With Ears
- ⑥ Material:N0-PA66 94V-0

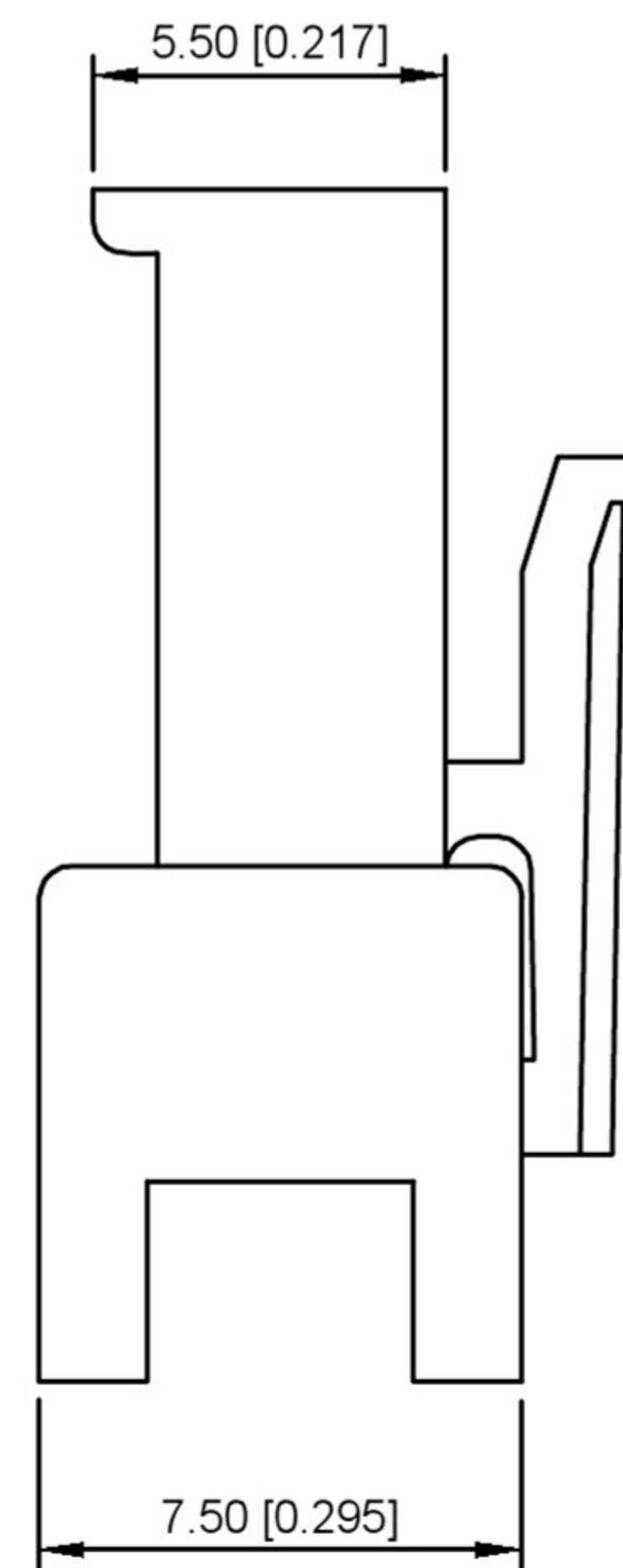
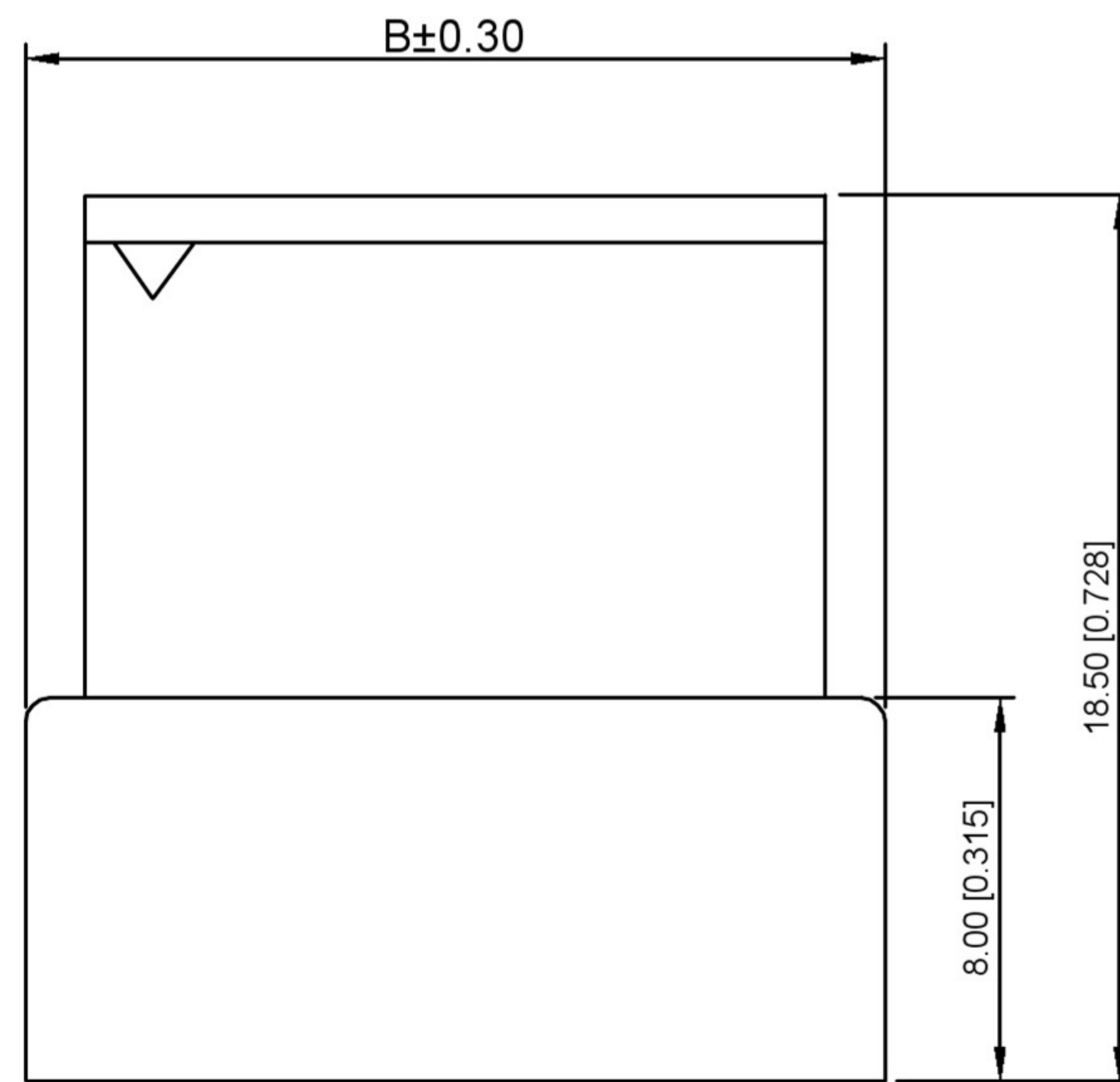

Poles	Dimensions(mm)		Poles	Dimensions(mm)	
	A	B		A	B
02	2.50	8.00	08	17.50	23.00
03	5.00	10.50	09	20.00	25.50
04	7.50	13.00	10	22.50	28.00
05	10.00	15.50	11	25.00	30.50
06	12.50	18.00	12	27.50	33.00
07	15.00	20.50			

X2521HF-XXG-N0	Black	PA66 UL 94V-0	Brass	Tin-Plated	X2521HM-G
PART NO	Color	Material	Material(Pin)	Finsh(Pin)	Suitable Terminal

REVISIONS				ANGLAR	±5°		DSND	SCALE: N/A	MODEL TYPE:
				L ≤ 4	±0.2		DWN	VIEW:	2.5mm Crimp Style Connector
				4 < L ≤ 16	±0.3		CHKD	UNIT: mm/in	PART NO.:
				16 < L ≤ 63	±0.4		APPD	SIZE: A4	XB-X0600WRS-XX-LPV01HF
DATE				REVISED	APPROVED			DWG NO.:	
				UNSPECIFIED TOLERANCES		DONG GUAN XI BANG ELECTRONIC CO., LTD			WEIGHT
www.alpsr.com www.gdxjdz.com www.xbswitch.com									SHEET
									1/1
									REVISION
									A0

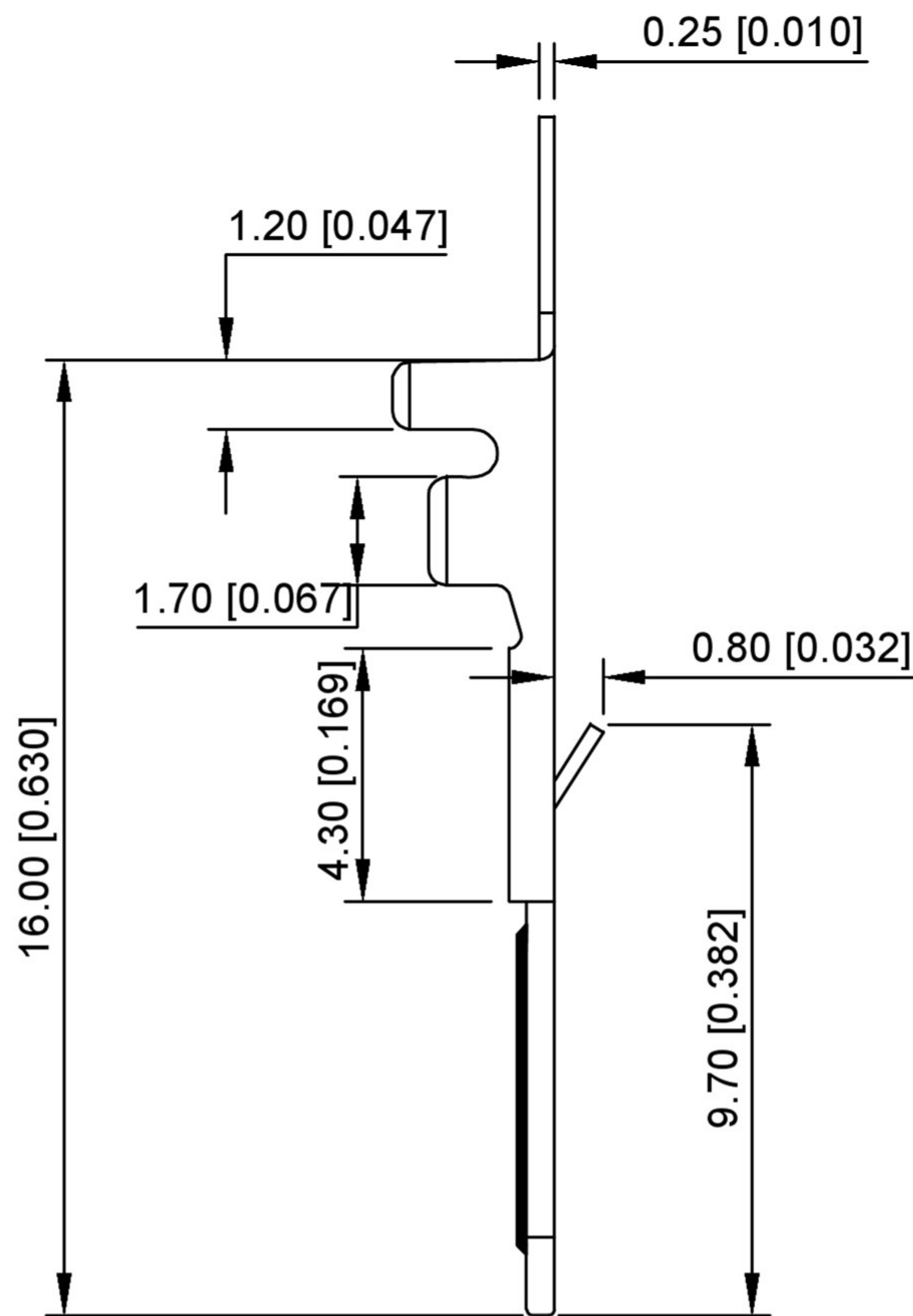
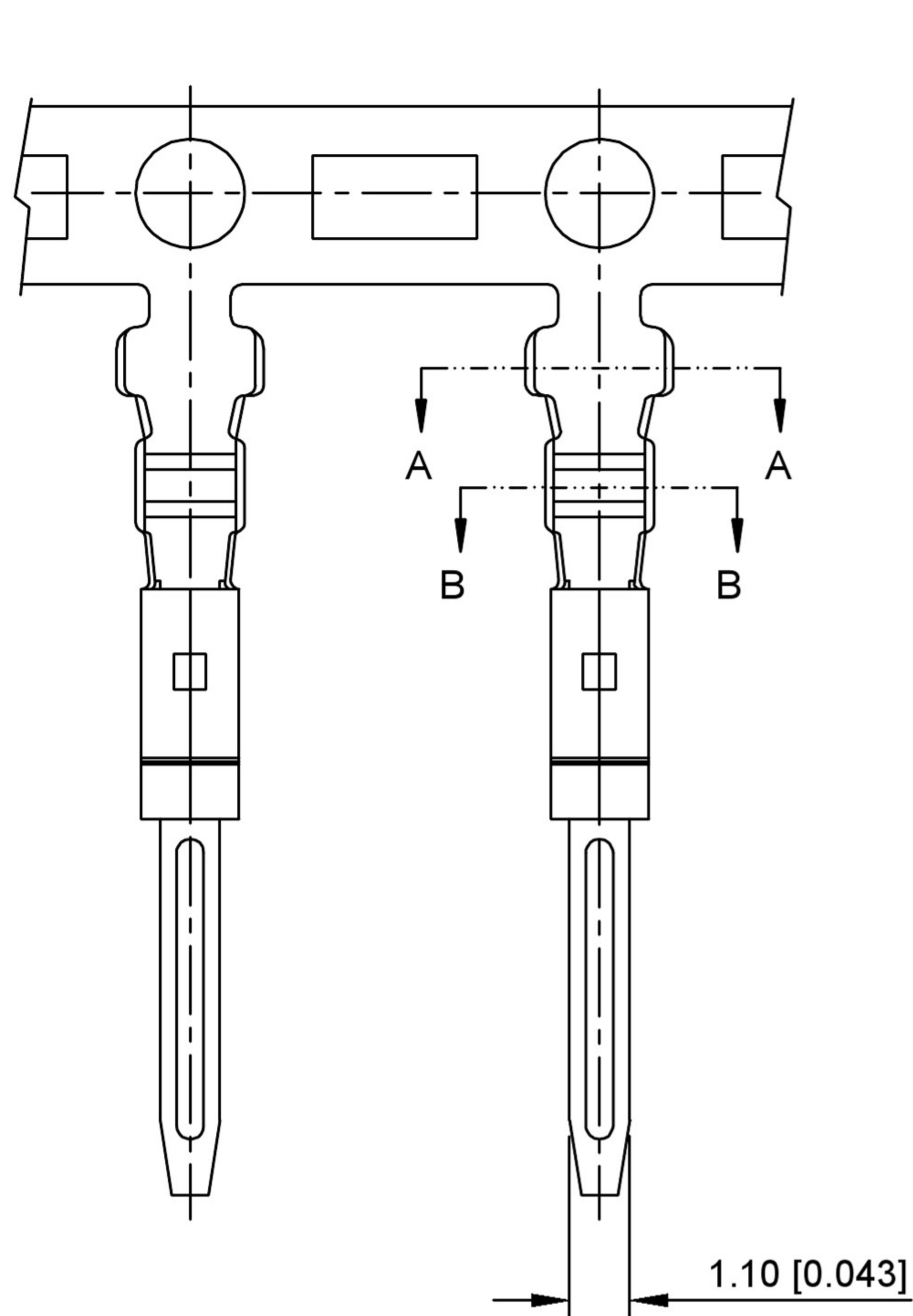

- 规格 Specifications:
- 额定电压 Voltage rating: 250V AC/DC
 - 额定电流 Current rating: 3A AC/DC
 - 耐电压 Withstanding voltage: 1500V AC/minute
 - 温度区间 Temperature range: -40°C ~ +105°C
 - 绝缘电阻 Insulation resistance: $\geq 500M\Omega$
 - 接触电阻 Contact resistance: $\leq 10m\Omega$
 - 环境测试后 After environmental testing: $\leq 20m\Omega$

X2521 T M- P SN-G
 ① ② ③ ④ ⑤ ⑥

- ① Series No.
- ② Category: T-Terminal
- ③ Welding Board Angle: M-male
- ④ Material: P-Phosphor Bronze
- ⑤ Plating style: SN-Bright tin plating
- ⑥ G:mating -G

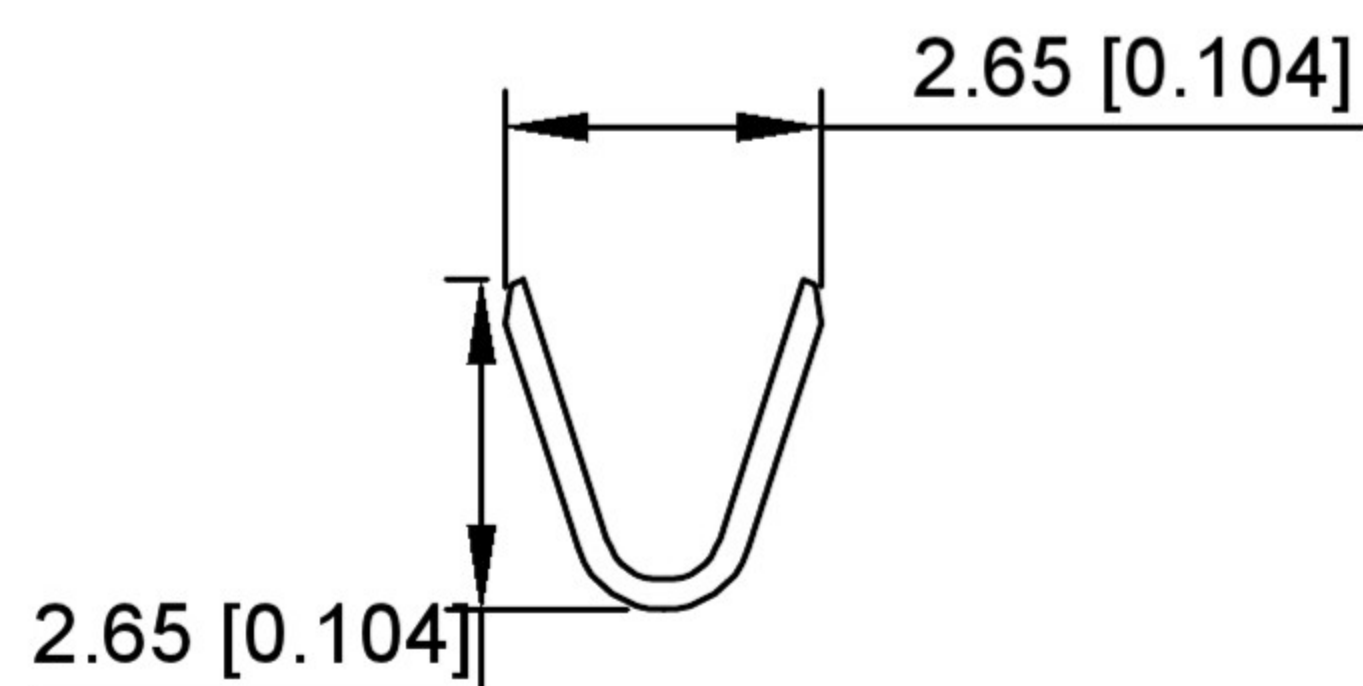

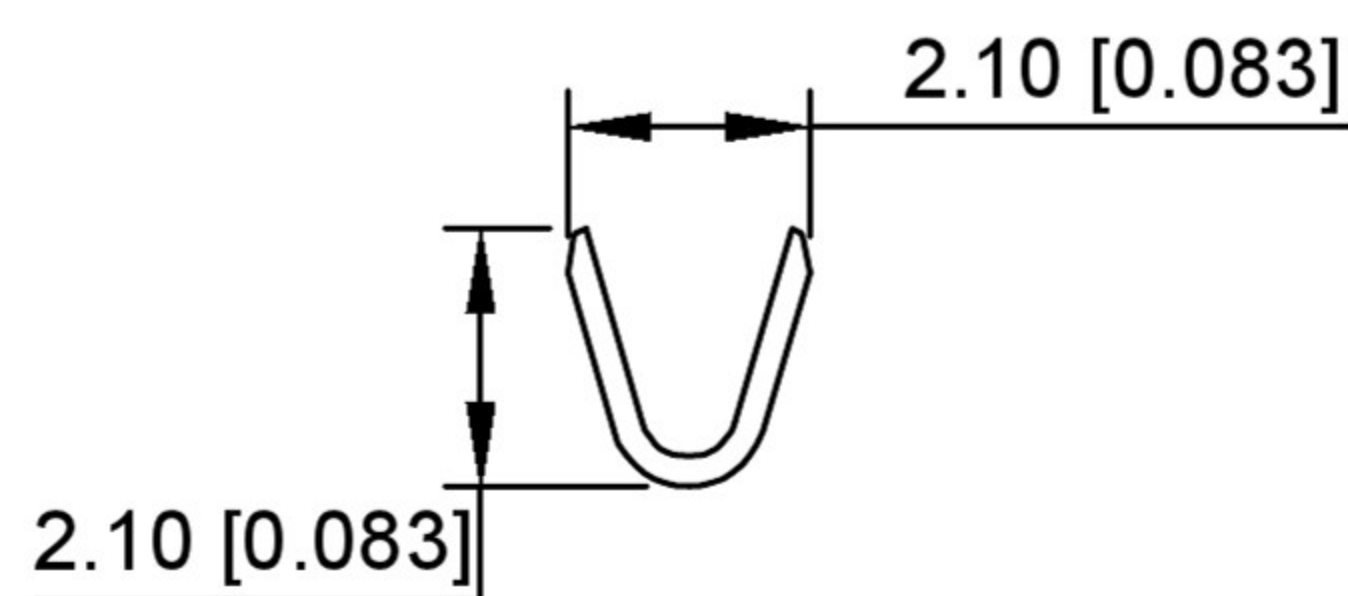

SEC:A-A



SEC:B-B

X2521TM-PSN-G	Phosphor Bronze	AWG#22-28	X2521HF
PART NO	Material	Wire Range	Suitable Housing

REVISIONS				ANGULAR	$\pm 5^\circ$		DSND	SCALE: N/A	MODEL TYPE:
DATE				$L \leq 4$	± 0.2		DWN	VIEW: 	2.5mm Crimp Style Connector
REVISED				$4 < L \leq 16$	± 0.3		CHKD	UNIT: mm/in	PART NO.:
APPROVED				$16 < L \leq 63$	± 0.4		APPD	SIZE: A4	XB-X0600WRS-XX-LPV01HF
				$L > 63$	± 0.5				DWG NO.:
UNSPECIFIED TOLERANCES				DONG GUAN XI BANG ELECTRONIC CO., LTD			WEIGHT	SHEET	REVISION
www.alpsr.com www.gdxjdz.com www.xbswitch.com								1/1	A0