

RoHS Compliant

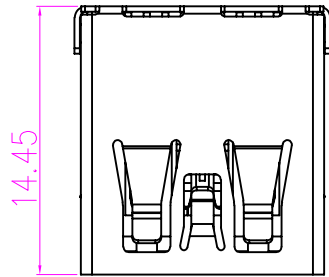

14.45

NO.	TITLE	Q'TY	MATERIAL
3	SHELL	1	BRASS
2	TERMINAL	9	BRONZE
1	Molding-ASSY	1	LCP

NOTE:

1. MATERIAL:
 - 1.1 INSULATOR:HIGH TEMPERATURE PLASTIC
 - 1.2 CONTACT:BRONZE,
 - 1.3 SHELL:BRASS,
2. ELECTRICAL CHARACTERISTICS;
 - 2.1 CONTACTRESISTANCE:30mΩ MAXIMUM
 - 2.2 CONTACT CURRENT RATING:1.5A
 - 2.3 DIELECTRIC WITHSTANDING VOLTAGE:100 V AC R. M. S.
 - 2.4 INSULATION RESISTANCE 100 MEGOHMS MIN
 - 2.5 OPERATING TEMPERATURE:-40° C ~ 85° C
- 3 MECHANICAL CHARACTERISTICS:
 - 3.1 MATING FORCE:3.57kgf MAX
 - 3.2 UNMATED FORCE:0.82kgf MIN AFTER TEST
 - 3.3 DURABILITY MANDATORY:1,500 CYCLES
 - 3.4 Salt Spray: 24 hours
4. PLATING
 - 4.1 TERMINAL:
 - 50u" NICKEL ALL OVER
 - 80u" Tin ON SOLDER AREA
 - (1~30)u"Au ON CONTACT AREA
 - 4.2 SHELL:50u"NICEL ALL OVER

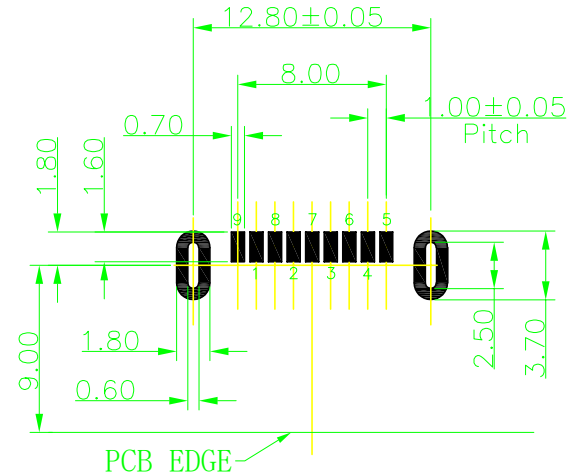
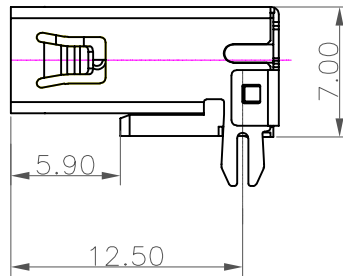
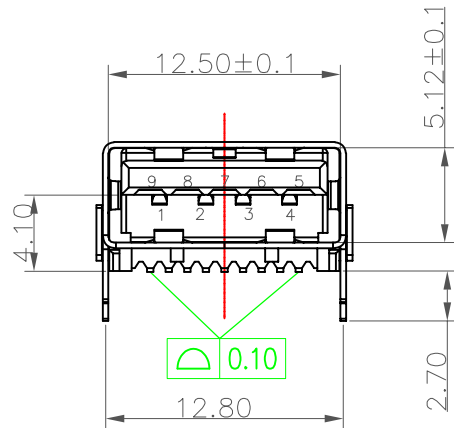

RECOMMENDED PCB LAYOUT
TOLERANCES: ±0.05

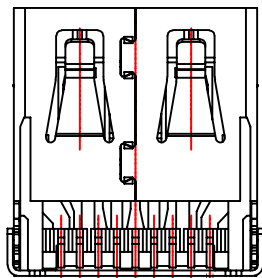

1.00±0.15, 8.00±0.15, 0.35±0.05

Pin NUMBER	SIGNAL NAME
1	VBUS
2	D-
3	D+
4	GND
5	StdA_SSRX-
6	StdA_SSRX+
7	GND_DRAIN
8	StdA_SSTX-
9	StdA_SSTX+
Shell	Shield

UNITS	SCALE	REV.	SHEET
(M)(M)	1:1	B3	1 OF 1
TOLERANCE		DATE	2021.11.08
X. ±0.50	X.* ±2'	DR.	Luoxi
.X ±0.30	.X* ±1'	CHK.	Luoxi
.XX ±0.10	.XX* ±0.5'	APPD.	Caitianlai
.XXX ±0.05			

东莞市溪榜电子有限公司
DONG GUAN XI BANG ELECTRONICS CO., LTD.

TITLE:
USB 3.0 AF 9P-F板上型后两脚SMT直边 鱼叉脚带后盖

MAT'L: SEE TABLE
FINISH: SEE TABLE

DWG.NO.: XB-USB-3.0-AF-9P-F
PART NO.: /
SIZE: A4