

CAD FILE:

ROHS

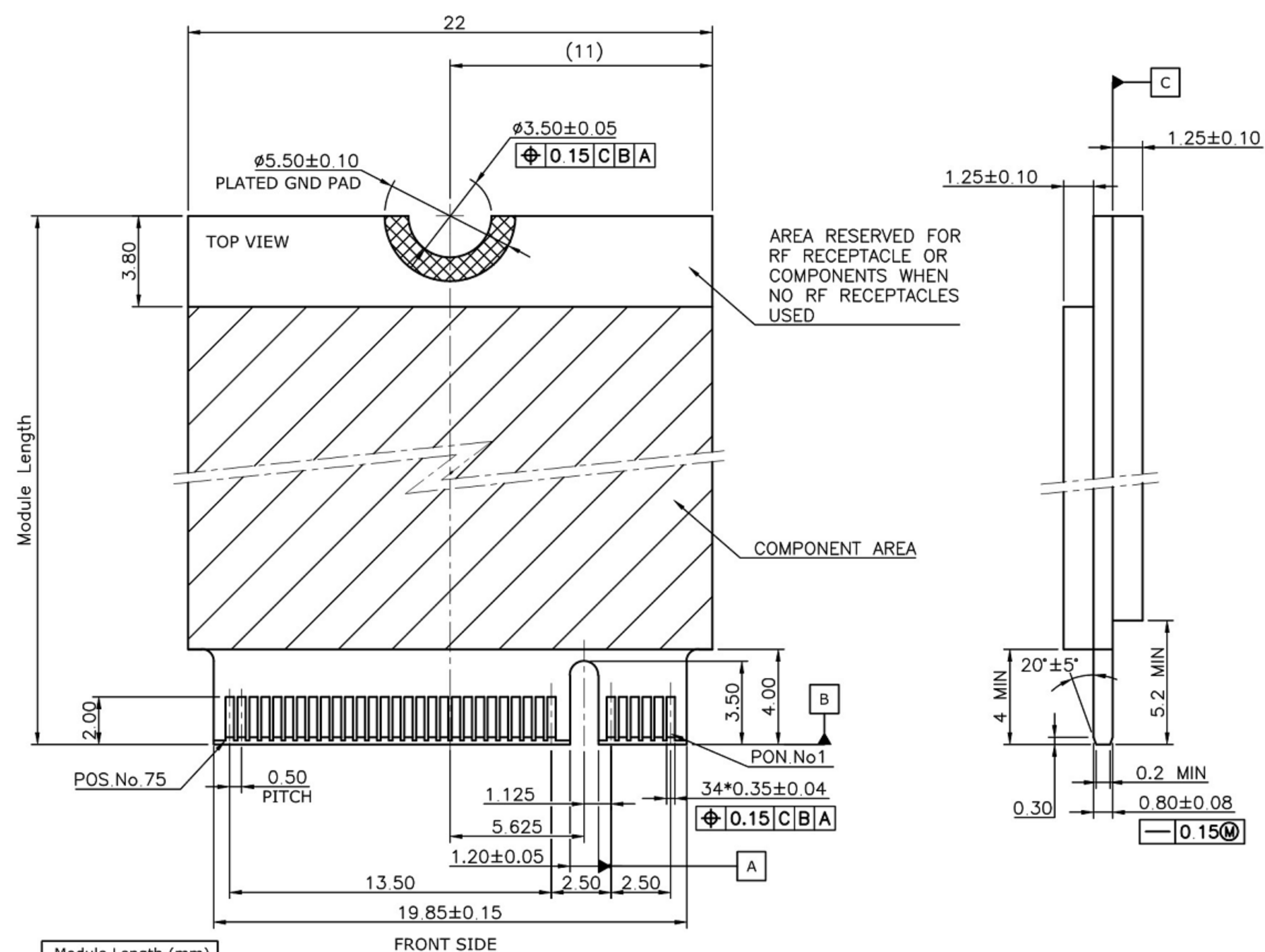

Module Length (mm)
42
60
80
110

KEY ID "B"
RECOMMENDED MODULE LAYOUT

REV.	DESCRIPTION	DRAWN	DATE
1	INITIAL RELEASE	FROS	2019/01/09
1.1	Corrected	FROS	2019/09/11

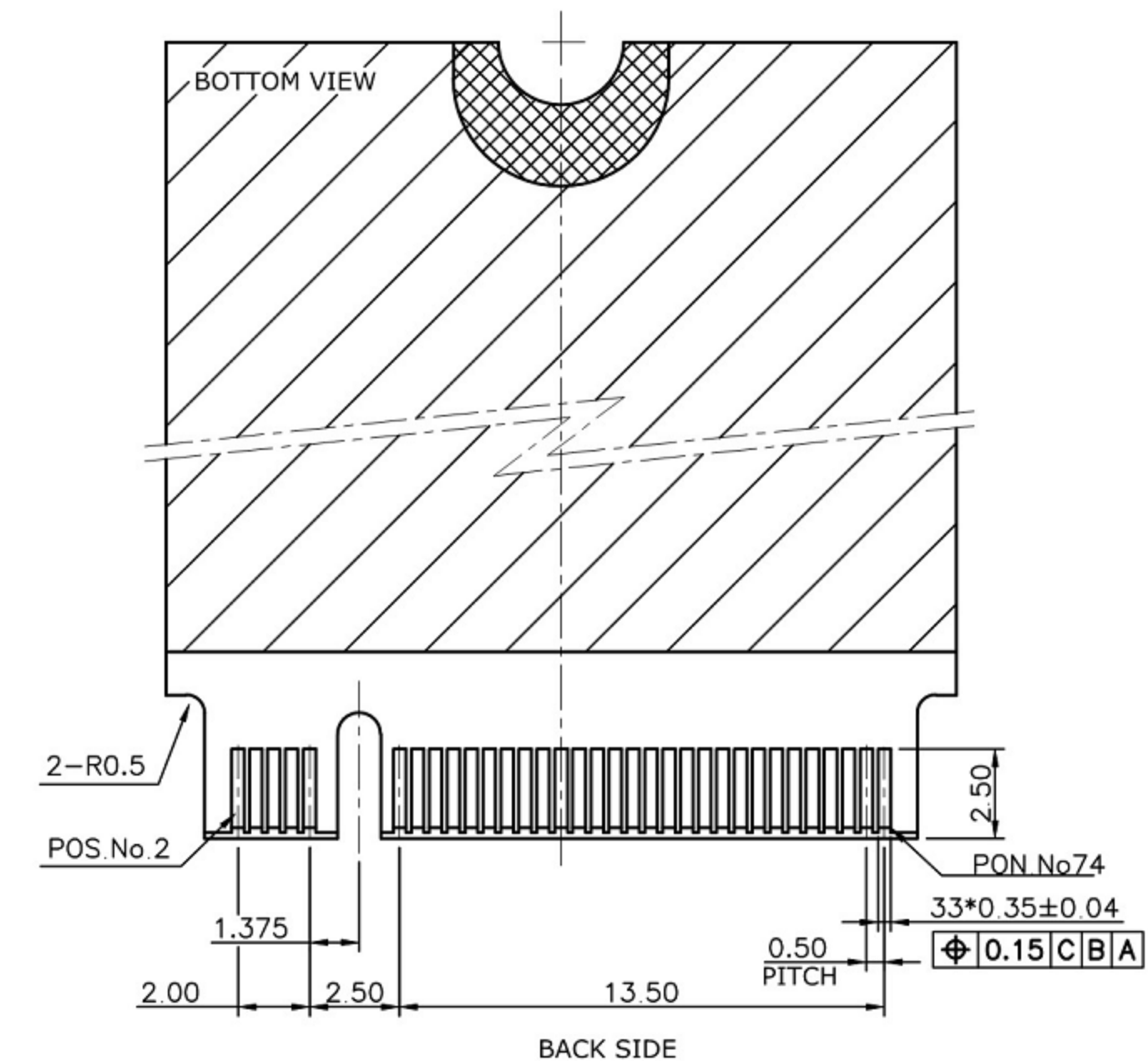

NO.	PARTS	MATERIALS	Q'TY	FINISH	TOLERANCE UNLESS SPECIFIED	ISSUE	DATE	DESCRIPTIONS OF REVISION	APPD.
8					WITHIN 1.5mm : ±0.1mm	A	2012-9-25	初版	ZENQ. CHEN
7					OVER 1.5mm : ±0.2mm	ISSUE	DATE	DESCRIPTIONS OF REVISION	APPD.
4	CONTACT	SUS	1	Ag CLAD	TITLE : PCB卡插座			UNIT : mm	DRWG NO.: XB-123A-30B00
3	CASE	PPA/BRASS SRTIP	1	BLACK/Ag PLATED	MODEL: PCB Card Socket			SCALE: 5:1	DWN. JUN. YANG 2012-9-25
2	COVER	STEEL STRIP	1	Ni PLATED	东莞市溪榜电子有限公司 DONG GUAN XI BANG ELECTRONICS CO., LTD.			CHK'D	DONG. PANG 2012-9-25
1	KNOB	PPA	1	BLACK				APPD.	ZENQ. CHEN 2012-9-25

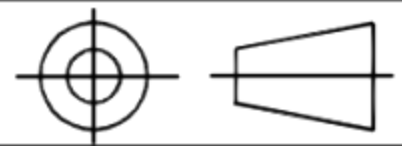

CAD FILE:

ROHS

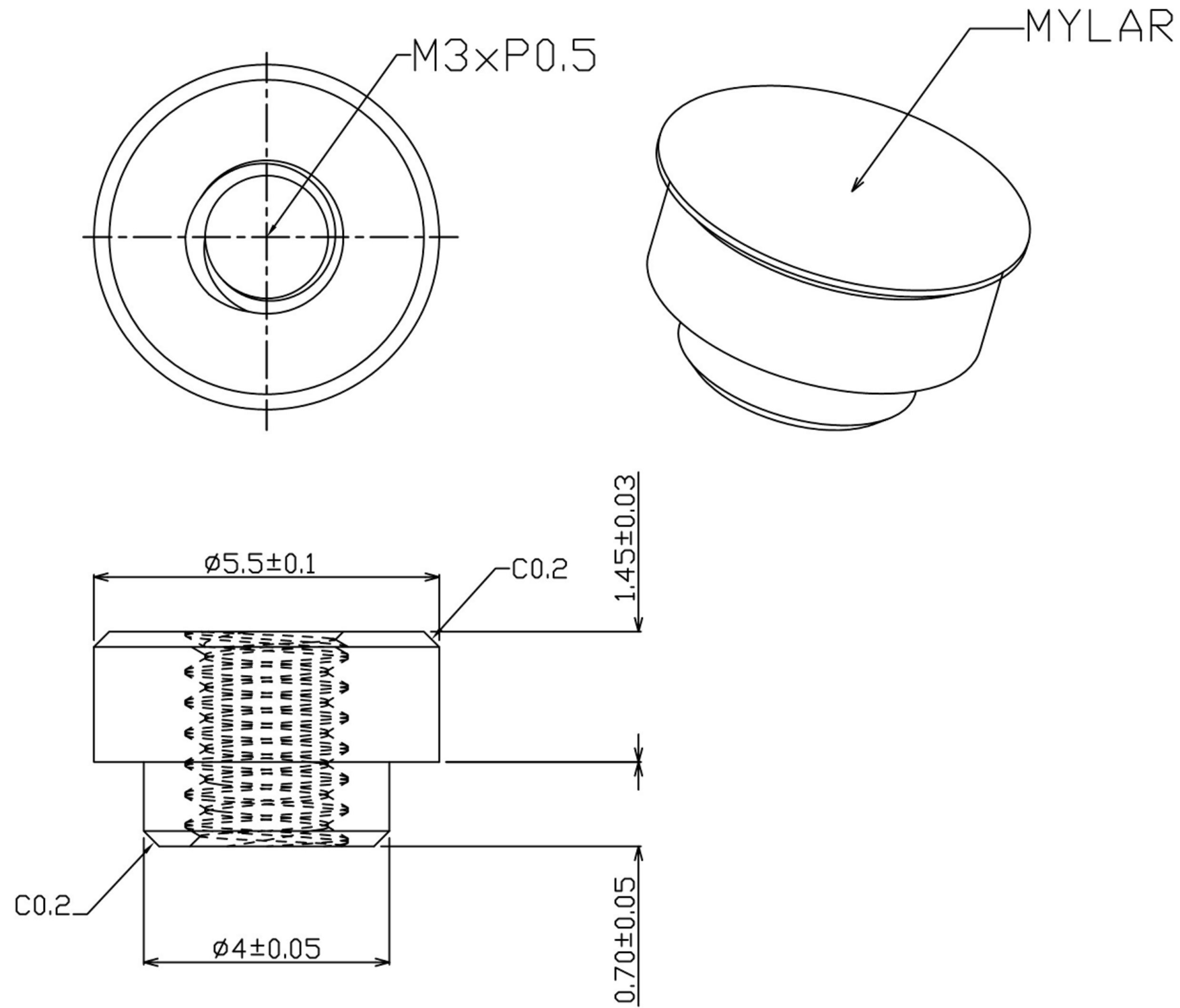

NOTE:
 1.MATERIAL: Copper Alloy
 2.Plating: Sn.

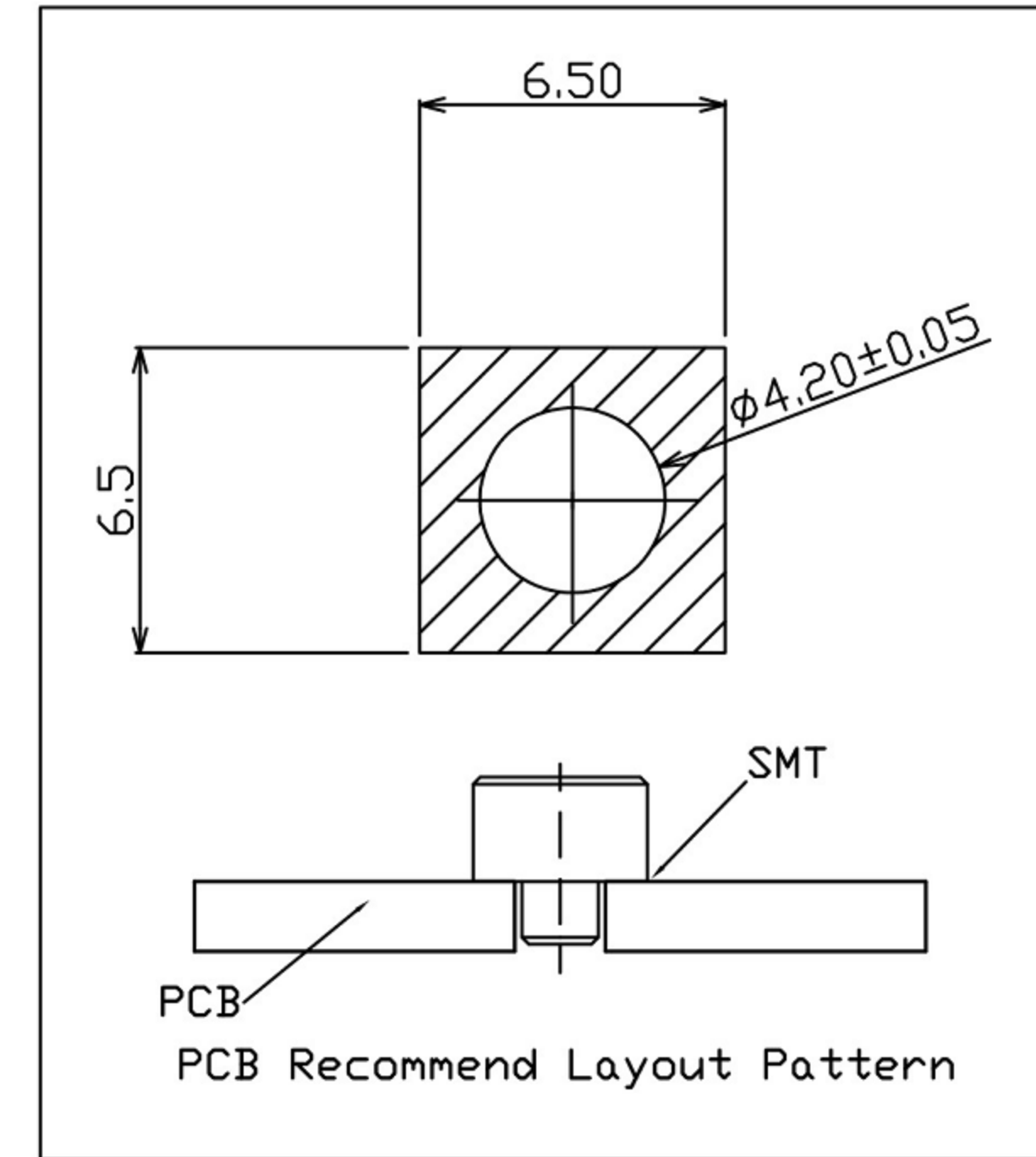

8					TOLERANCE						
7					UNLESS SPECIFIED						
6					WITHIN 1.5mm : ±0.1mm	A	2012-9-25	初版		ZENQ. CHEN	
5					OVER 1.5mm : ±0.2mm	ISSUE	DATE	DESCRIPTIONS OF REVISION		APPD.	
4	CONTACT	SUS	1	Ag CLAD	TITLE : PCB卡插座			UNIT : mm	DRWG NO.: XB-123A-30B00		
3	CASE	PPA/BRASS SRTIP	1	BLACK/Ag PLATED	MODEL: PCB Card Socket			SCALE: 5:1	DWN.	JUN. YANG	2012-9-25
2	COVER	STEEL STRIP	1	Ni PLATED	东莞市溪榜电子有限公司 DONG GUAN XI BANG ELECTRONI CS CO., LTD.				CHK'D	DONG. PANG	2012-9-25
1	KNOB	PPA	1	BLACK					APPD.	ZENQ. CHEN	2012-9-25
NO.	PARTS	MATERIALS	Q'TY	FINISH							

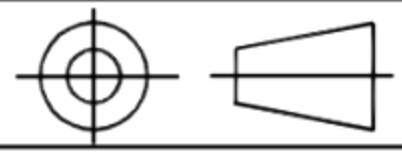

CAD FILE:

ROHS

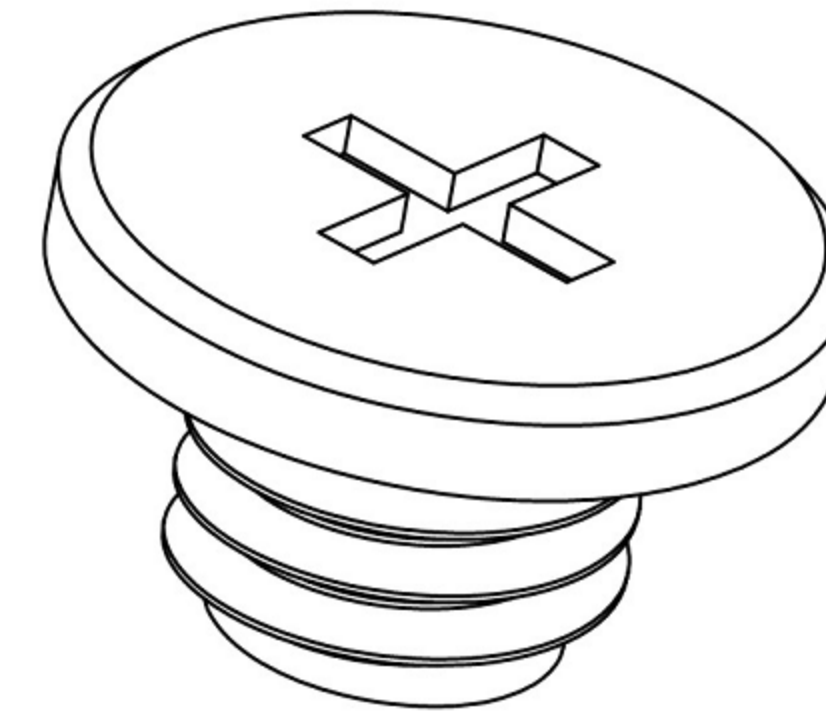
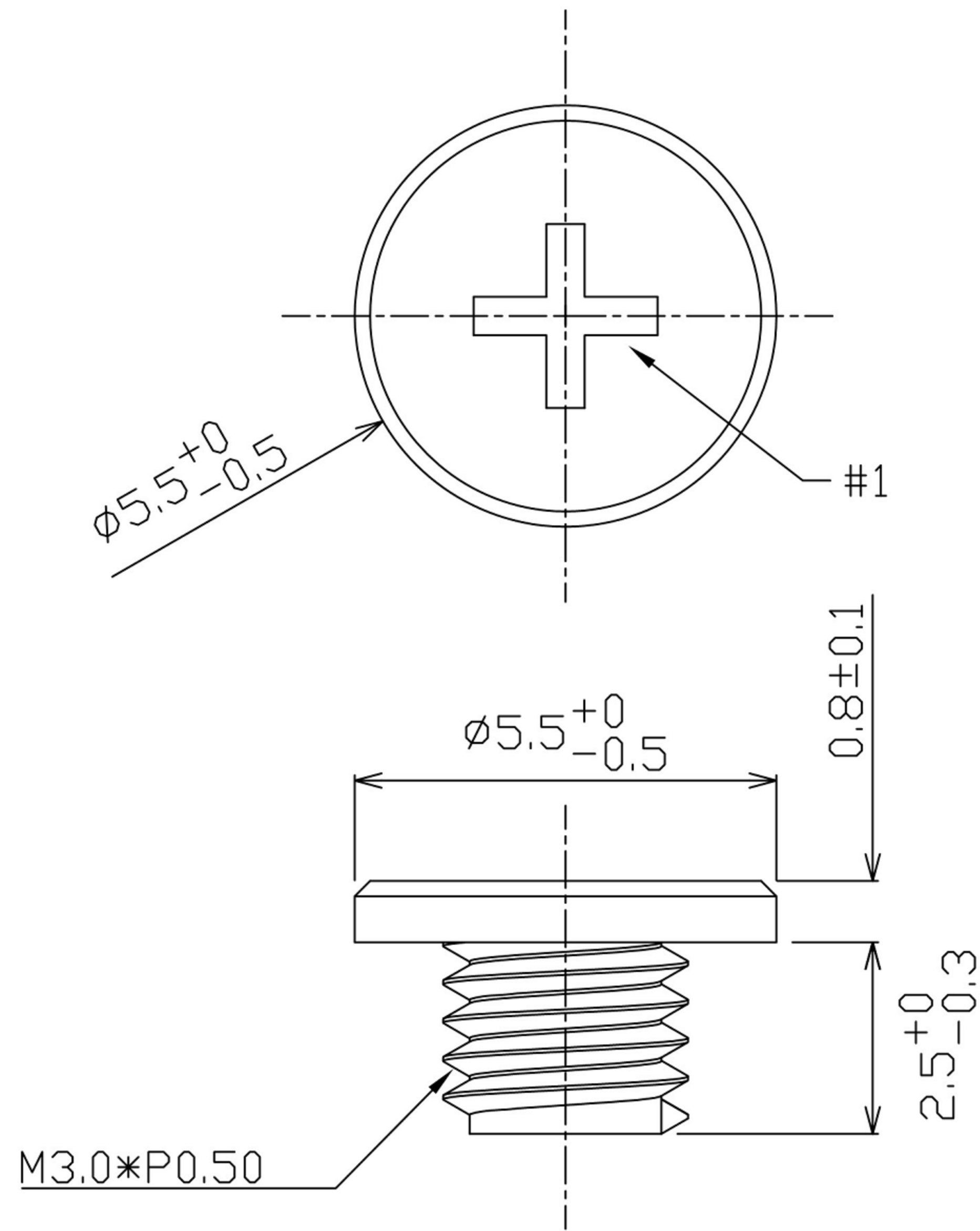

Note:

1. Material: Low-carbon steel
2. Plating: Nickel

NO.	PARTS	MATERIALS	Q'TY	FINISH	TOLERANCE UNLESS SPECIFIED		DESCRIPTIONS OF REVISION		
8					WITHIN 1.5mm : ±0.1mm	A	2012-9-25	初版	
7					OVER 1.5mm : ±0.2mm	ISSUE	DATE	ZENQ. CHEN	
6					APPD.				
5					TITLE : PCB卡插座				
4	CONTACT	SUS	1	Ag CLAD	MODEL: PCB Card Socket		UNIT : mm	DRWG NO.: XB-123A-30B00	
3	CASE	PPA/BRASS SRTIP	1	BLACK/Ag PLATED	SCALE: 5:1	DWN.	JUN. YANG	2012-9-25	
2	COVER	STEEL STRIP	1	Ni PLATED	CHK'D	DONG. PANG	2012-9-25		
1	KNOB	PPA	1	BLACK	APPD.	ZENQ. CHEN	2012-9-25		
					东莞市溪榜电子有限公司 DONG GUAN XI BANG ELECTRONI CS CO., LTD.				

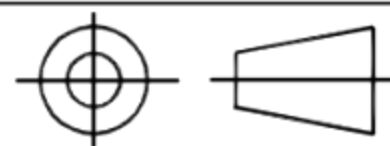

CAD FILE:

ROHS

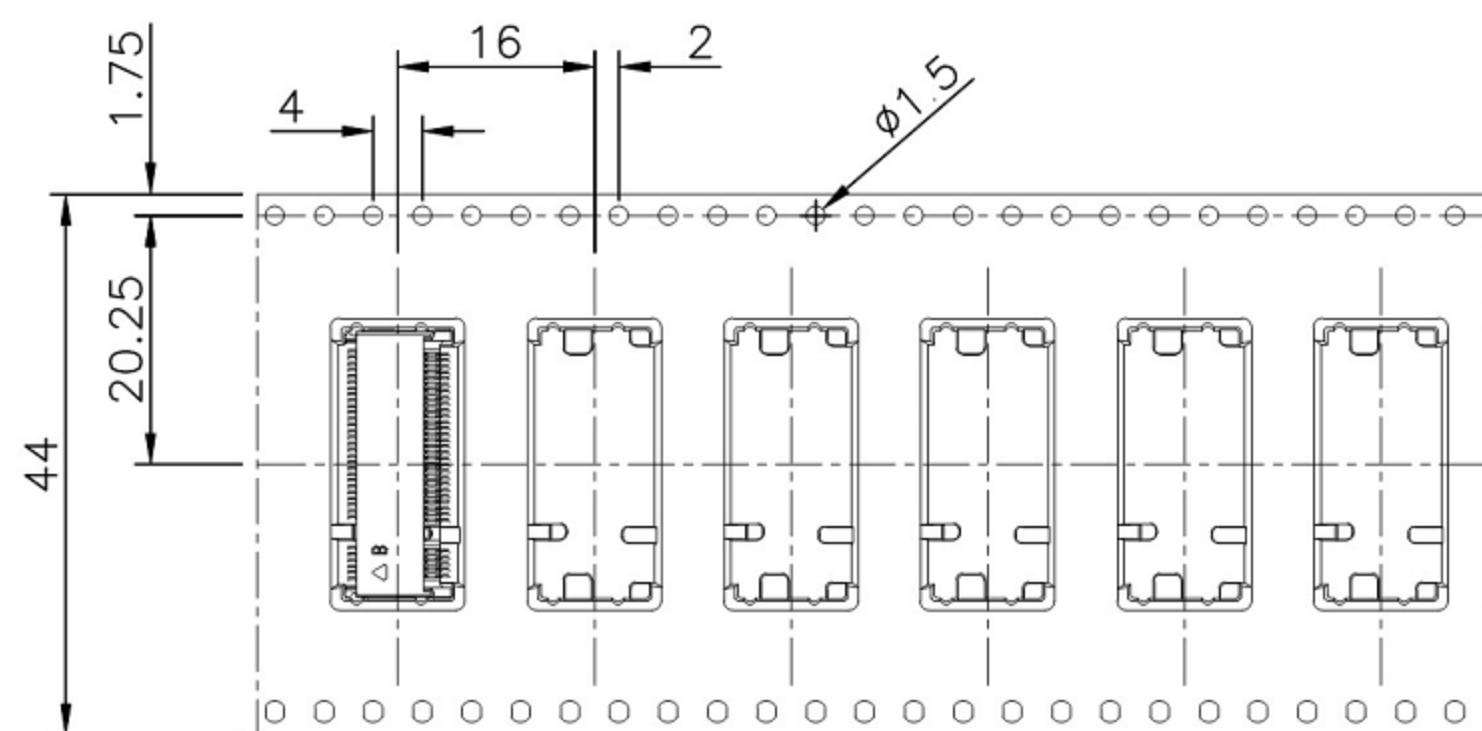
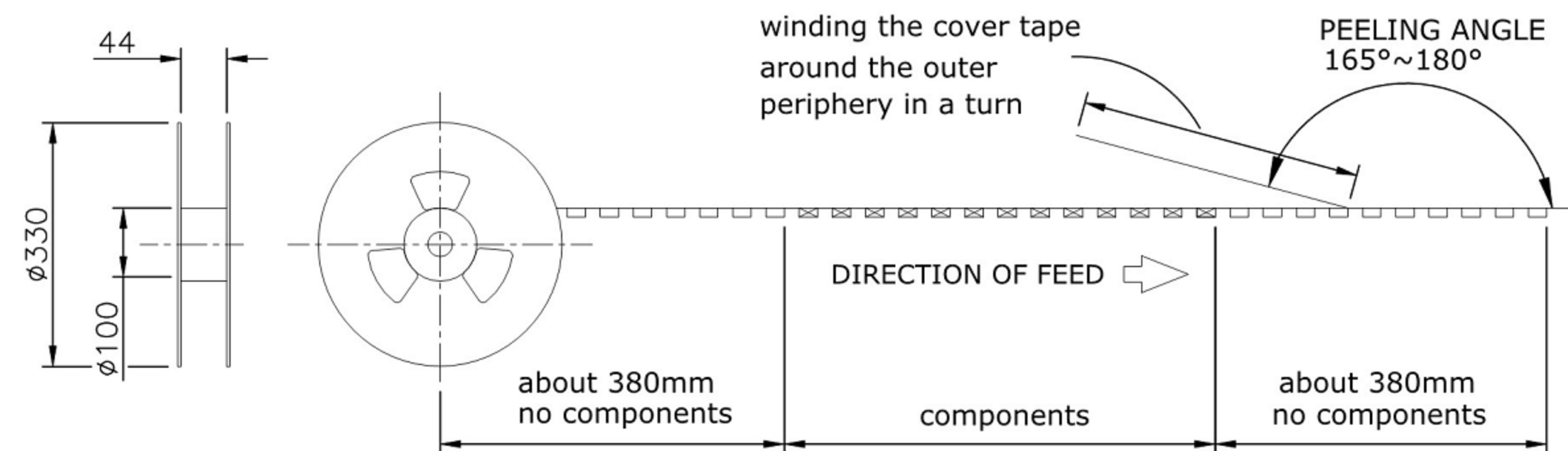

PACKAGING SPECIFICATION:

1. MATERIAL

- 1.1 Embossed Carrier Tape: PS Black
- 1.2 Top Cover Tape: PET
20-80g(Peel Speed 300mm/Minute)
- 1.3 Taping Reel: Plastic

2. Packaging:

P/N	Height	Reel	Carton
123A-21X00	2.15	1200	7200
123A-30X00	3.05	900	5400
123A-40X00	4.05	700	4200
123A-58X00	5.80	600	3600

REV.	DESCRIPTION	DRAWN	DATE
1	INITIAL RELEASE	TIM	2018/01/19

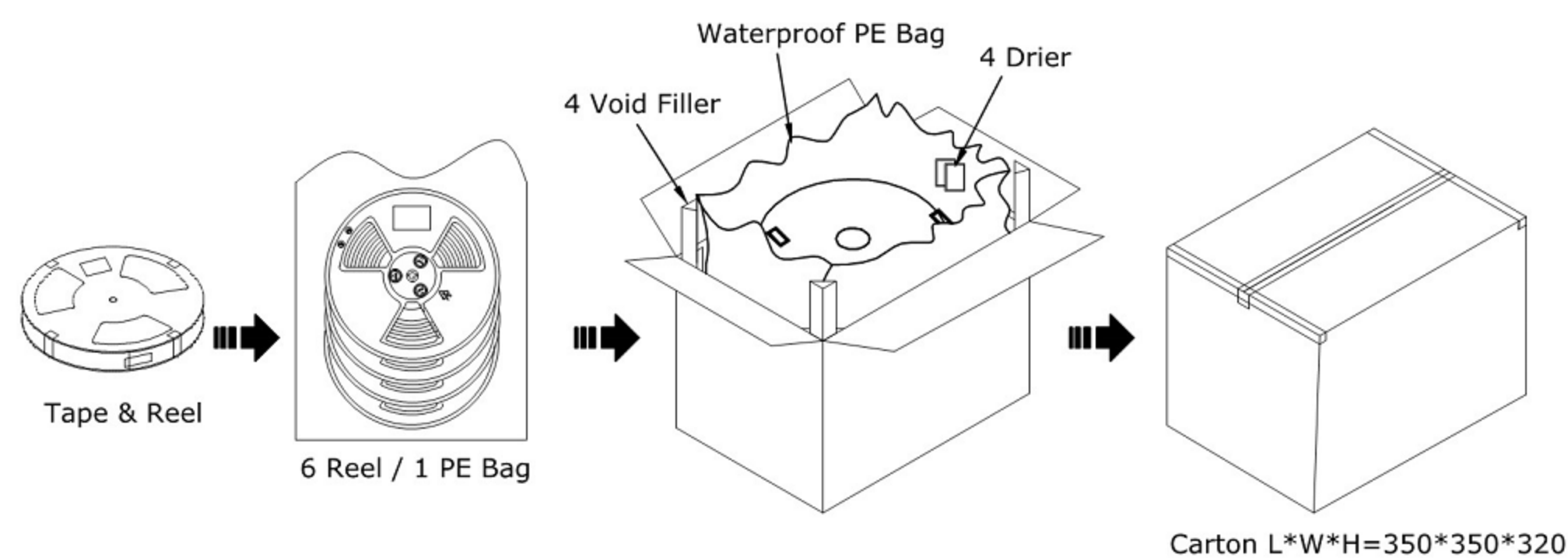

NO.	PARTS	MATERIALS	Q'TY	FINISH	TOLERANCE UNLESS SPECIFIED	ISSUE	DATE	DESCRIPTIONS OF REVISION	APPD.
8									
7									
6					WITHIN 1.5mm : ±0.1mm	A	2012-9-25	初版	ZENQ. CHEN
5					OVER 1.5mm : ±0.2mm	ISSUE	DATE	DESCRIPTIONS OF REVISION	APPD.
4	CONTACT	SUS	1	Ag CLAD	TITLE : PCB卡插座			UNIT : mm	DRWG NO.: XB-123A-30B00
3	CASE	PPA/BRASS SRTIP	1	BLACK/Ag PLATED	MODEL: PCB Card Socket			SCALE: 5:1	DWN. JUN. YANG 2012-9-25
2	COVER	STEEL STRIP	1	Ni PLATED	东莞市溪榜电子有限公司 DONG GUAN XI BANG ELECTRONI CS CO., LTD.			CHK'D	DONG. PANG 2012-9-25
1	KNOB	PPA	1	BLACK				APPD.	ZENQ. CHEN 2012-9-25