

RECOMMENDED PCB LAYOUT
TOP VIEW TOLERANCE: ± 0.05

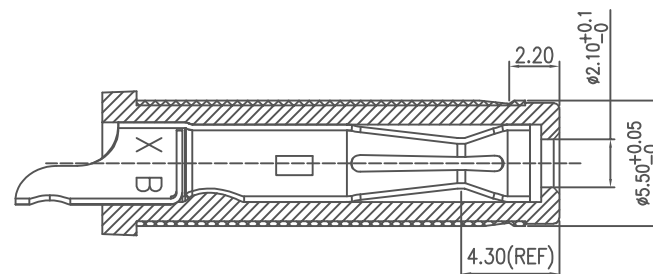
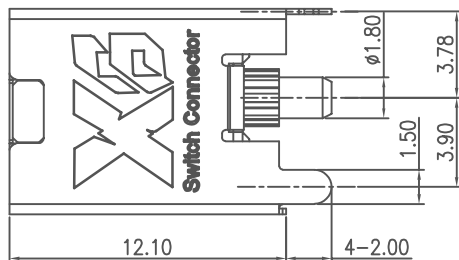
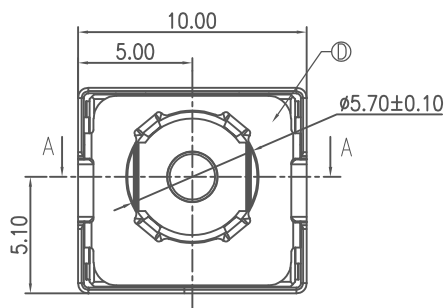

MATING PLUG
DP550200-0129-60000H

SPECIFICATION:

1. RATING: DC 20V 20A
2. CONTACT RESISTANCE:
30m Ω MAX.(INITIAL)
50m Ω MAX.(FINAL)
3. INSULATION RESISTANCE: 100 M Ω MIN.
4. WITHSTAND VOLTAGE: 500 VAC
5. INSERTION FORCE: 3N~30N
6. EXTRACTION FORCE: 3N~30N
7. DURABILITY: 5,000 CYCLES

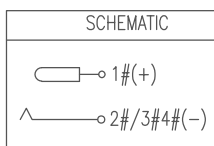

NO.	DESCRIPTION	MATERIAL	REMARKS	QTY
E	COVER	HIGH TEMP.THERMOPLASTIC	BLACK	
D	GROUND	SUS 304		1
C	SHELL	COPPER ALLOY	Ni 40 μ "MIN.	1
B	CENTER PIN	BRASS	GOLD FLASH/Ni 40 μ " MIN.	1
A	HOUSING	HIGH TEMP.THERMOPLASTIC	BLACK	1

UNLESS OTHERWISE SPECIFIED TOLERANCES

XB 东莞市溪榜电子有限公司
DONG GUAN XI BANG ELECTRONICS CO., LTD.

DECIMALS:		ANGLES:		DESIGN:	GAO. PENG	PART NAME: Φ5.5 立式(H=12.1) DC POWER JACK	
DIM	TOL	DIM	TOL	CHECK:	2023.3.28		
X.	±0.50	X.	±2°	APPROVED	HE. LONG. FEI 2023.3.28	PART NO. XB-DC-550200-1696	
X.X	±0.30	X.X	±1°			SHEET: 1/2	REV.: A1
X.XX	±0.20	X.XX				DRAWING NO	
X.XXX	±0.10	X.XXX					

REV.	ECN NO.	DESCRIPTION	DESIGN	DATE
8				
7				
6				
5				



UNIT:
mm

8

7

6

5

4

3

2

1

1