

IPX7

ROHS

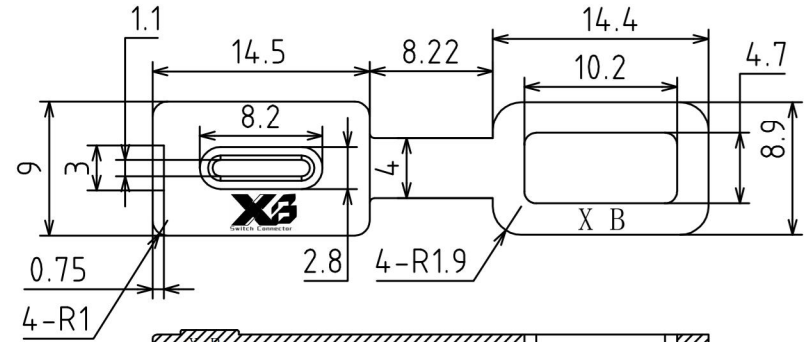
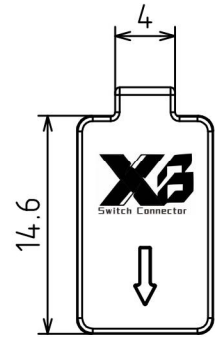
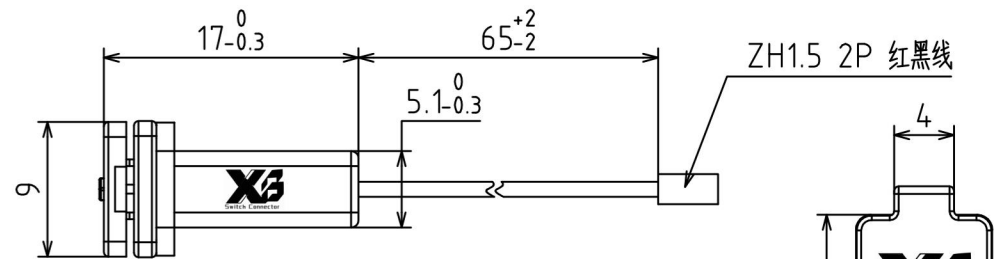

材质耐老化硅胶 灰白色

NOTES:

- MATERIAL:
 - MOLDING: LCP UL94 V-0
 - CONTACT: COPPER ALLOY.
 - GOLD PLATED Min ON CONTACT AREA, 100u" Min TIN (LEAD FREE) ON SOLDER AREA,
 - SHELL: SUS201-H, T=0.25±0.03mm
 - 50u" NICKEL PLATING OVER ALL.
- MECHANICAL:
 - INSERTION: 5~20N.
 - EXTRACTION: 8~20N AFTER TEST.
 - DURABILITY: 5000 CYCLES
- ELECTRICAL:
 - CURRENT: 3A FOR VBUS; 1.25A FOR GND PIN. 0.25A FOR OTHER.
 - VOLTAGE: 20 V MAX
 - WITHSTANDING VOLTAGE: 100V AC R.M.S.
 - CONTACT RESISTANCE: 40mΩ MAX.
 - INSULATION RESISTANCE: 100MΩ MIN.
- ENVIRONMENTAL
 - TEMPERATURE RANGE -25°C ~ +85°C
- 尺寸标注事项: 图示有标示者为首样全检, 重点管控尺寸.
- 产品符合RoHS标准.

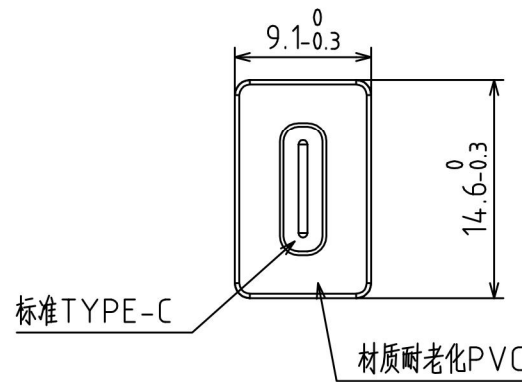
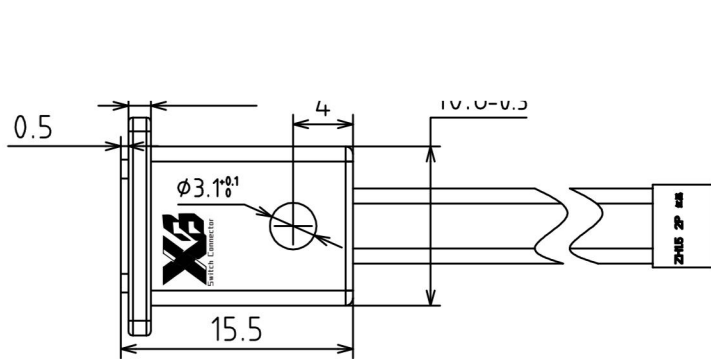
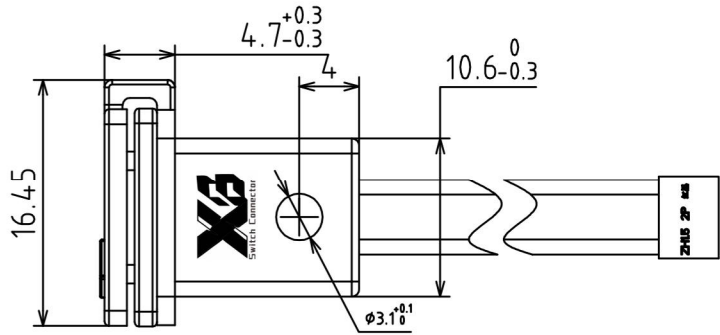

XB 东莞市溪榜电子有限公司
Switch Connector DONG GUAN XI BANG ELECTRONICS CO., LTD

TOLERANCE UNLESS OTHERWISE STATED:
 Up to 5 ±0.2
 Above 5 ~ 15 ±0.3
 Above 15 ~ 30 ±0.4
 Above 30 ~ 50 ±0.5
 Angle ±0.3°

3RD. ANGEL'S



UNITS MM

DRAWN BY: ZENQ. CHEN
 CHECKED BY: DONG. PANG
 APPROVED BY: FEI. LONG. HE

DATE: 03/07/23
 DATE: 03/07/23
 DATE: 03/07/23

MAT'L		TITLE	CONNECTOR
FINISH		MODLE	USB TYPE CF
SCALE	1 : 1	DWG NO.	USB C TYPE 2.0 Female 防水型
SHEET NO.	1 of 1	PART NO.	XB-TYPEC-023B-H155-P2
		SIZE	A4
		VER	R

ITEM NO. DESCRIPTION DRAWN DATE