

ROHS

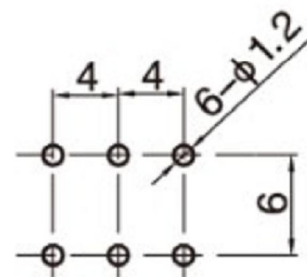

PCB LAYOUT

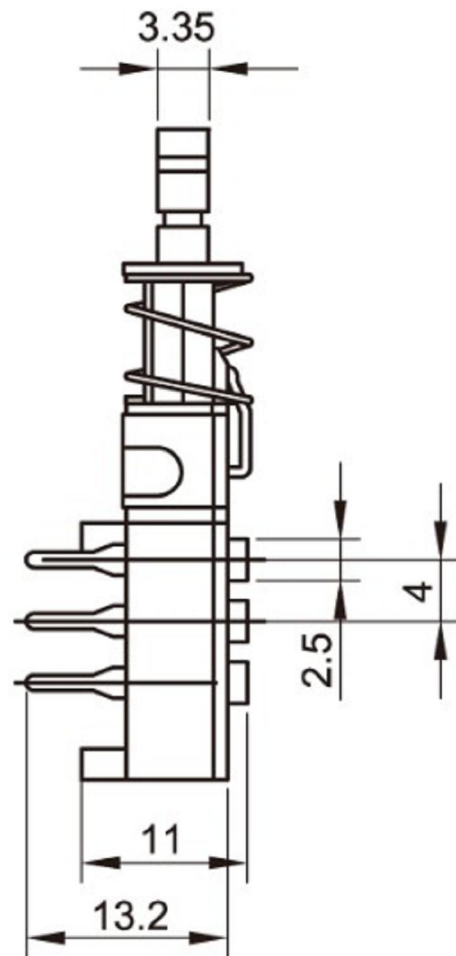
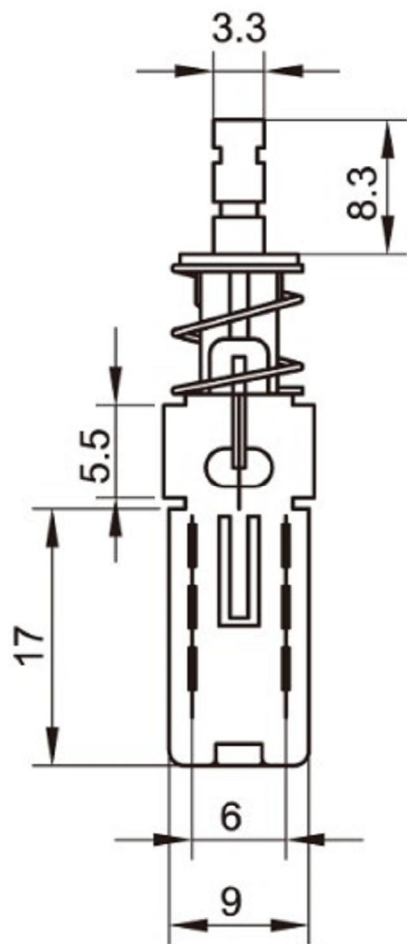
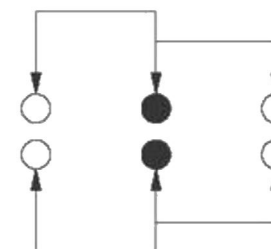

SCHEMATIC

ITEM: PERFORMANCE

Title: PUSH BUTTOMN SWICH

Model: XB-PBS-Z2-1

Rating: 0.3A 0.5A 12V 30V DC

Function: 2P2T

Timing:Non-shorting

ContactResistance(mohms):50mΩ max

Insulation Resistanc(Mohms):100MΩ min at 500V DC

Dielectric Strength(V):AC 500V for 1 min

LifeTest:10,000 Cycles



东莞市溪榜电子有限公司
DONG GUAN XI BANG ELECTRONICS CO., LTD

TITLE : XB PUHS BUTTON SWITCH

MODEL : XB-PBS-Z2-1 全塑按钮开关六脚卧式

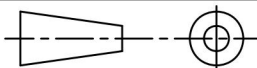

TOLERANCE
<=1.5mm ± 0.1
>1.5mm ± 0.2
>=10mm ± 0.3

ANGLE
± 2°

8	CONTACT CLIP	PBS STRIP	2	Ag CLAD
7	RING	IRON STRIP	1	Zn PLATED
6	SPRING	SUS	1	NATURE
5	SLEEVE	POM	1	GRAY
4	CASE	NYLON	1	GRAY
3	COVER	PBT	1	GRAY
2	TERMINAL	BRASS STRIP	6	Ag PLATED
1	KNOB	POM	1	YELLOW
NO.	PART NAME	MATERIAL	QTY.	FINISHING

UNIT :	MM	DWN.	ZENQ. CHEN	DATE	2024-05-08
SCALE :	3 : 1	CHK'D	PANG. DONG	DATE	2024-05-08
VERSION	01	APPD.	FEI. LONG. HE	DATE	2024-05-08