

Materials:

- * Insulator: Glass filled polyester UL 94V-0
- * Contacts: Copper alloy

△ * Shell: Steel, Nickel plated as standard

Recommended P.C. Board Layout see drawing No. CD0304S*

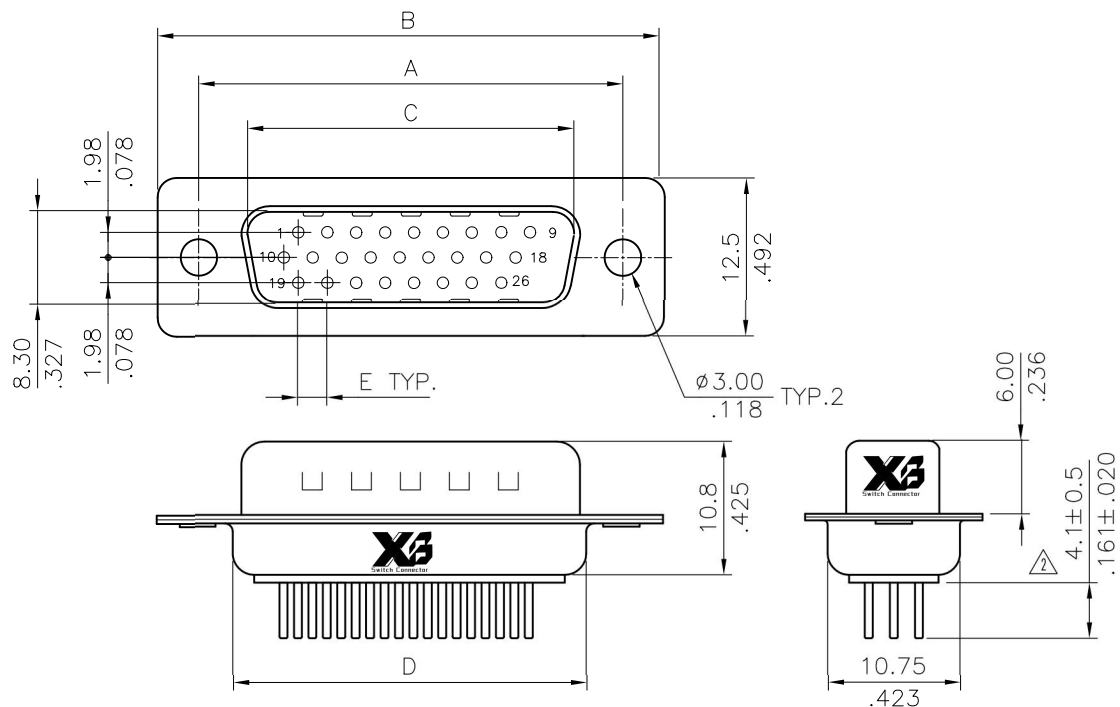

Circuits	Dimension				
	A	B	C	D	E
15	25.00(.984)	30.8(1.213)	16.92(.666)	19.20(.756)	2.29(.090)
26	33.32(1.312)	39.2(1.543)	25.25(.994)	27.70(1.091)	2.29(.090)
44	47.04(1.852)	53.1(2.091)	38.96(1.534)	41.10(1.618)	2.29(.090)
62	63.50(2.500)	69.4(2.732)	55.42(2.182)	57.30(2.256)	2.41(.095)

Ordering Code :

CD03 26 P A 1 00
 ① ② ③ ④ ⑤ ⑥

- ① Series No.
- ② No. of Circuits
- ③ Contact type: P= Plug(Male)
- ④ Plating code:
 2= Gold flash plated over Nickel
 A= Selective Gold flash plated over Nickel
 B= Selective 0.38μm(15μ") Gold plated over 1.27μm(50μ") Nickel
 C= Selective 0.76μm(30μ") Gold plated over 1.27μm(50μ") Nickel
- ⑤ Color: 1= Black
- ⑥ Mounting style:
 △00= With ø3.00mm holes on shell(Standard)
 B0= Riveted #4-40 UNC open nuts on front shell
 C0= Riveted #4-40 UNC open nuts on rear shell
 △D0= Riveted #4-40 UNC ground stand-off on rear shell

Lead Free Process

RoHS Compliant

Mounting Style

Code	00	Code	B0	Code	C0	Code	D0
			DIM. L= 4.0mm		DIM. L= 3.2mm		DIM. L= 6.0mm

△4	Ken	3/12-18'	ECRT117079/ECNT118047		DATE	UNIT: mm / inch	TITLE: HIGH-DENSITY D-SUB TOP ENTRY BOARD MOUNT MALE CONNECTOR	东莞市溪榜电子有限公司 DONG GUAN XI BANG ELECTRONICS CO., LTD			
△3	Sandy	3/25-10'	ECN10079	DRAWN BY: Ken	3/12-18'	TOLERANCE UNLESS OTHERWISE SPECIFIED	MATERIAL:				
△2	Karen	9/18/08'	ECN08458/ECR08074-0	ENGINEER: Sun	3/13-18'	.X ± 0.30/012 X' ± 1'	FINISH:	DRAWING NO.	CD0302SH	PART NO.	CD03**P*1**
△1	SUN	8/27/03'	ECN03269	CHECKED BY: Eislely	3/15-18'	.XX ± 0.20/010 X' ±		SCALE	2 / 1	SHEET	1 OF 1
SYM	NAME	DATE	REVISIONS	APPROVED BY: Eislely	3/15-18'	.XXX ± 0.10/004 X' ±					